

Aljon

**Keeping It Simple
Building It Strong**

#20 Automatic Car Crusher

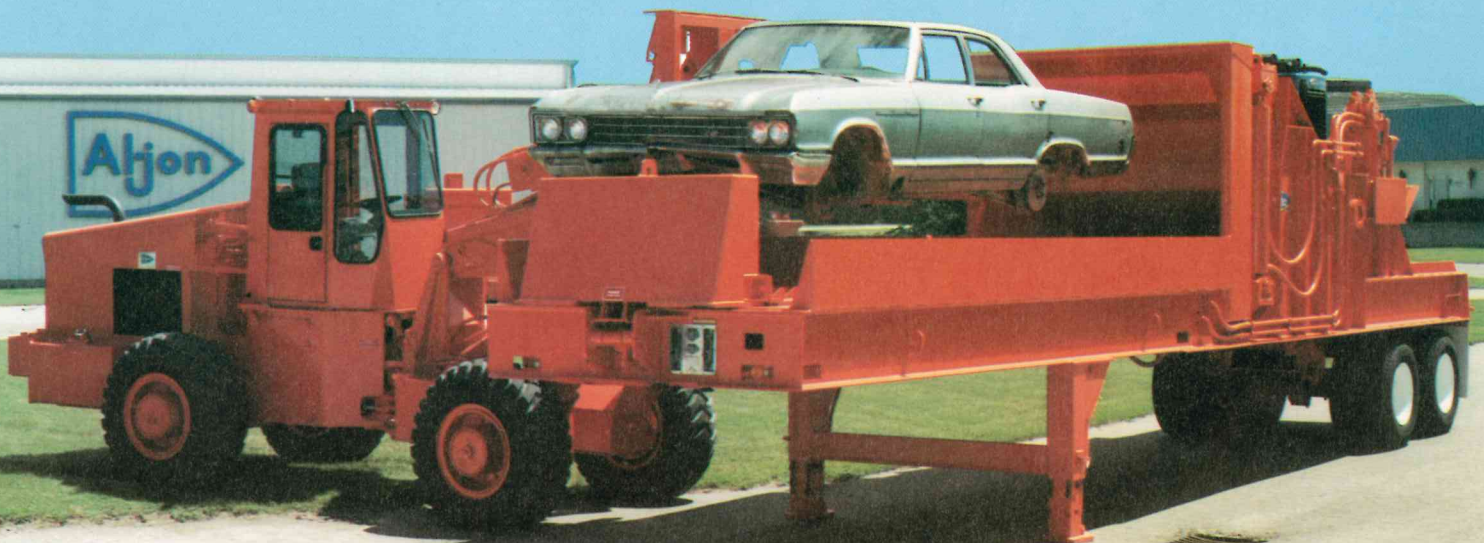

- AUTOMATIC REMOTE CONTROL
- DOUBLE CRUSHING
- LOAD LEGAL
- NO SET-UP

NEW! OIL RECOVERY SYSTEM!

#20



Refr

Portable Car Crusher



OIL RECOVERY SYSTEM

The only crusher available with this unique feature. Leave the yard clean, avoid any EPA violations, and still gain the many benefits of Al-Jon superior crushing abilities. Recovers approximately 80 gallons of fluids for every 100 cars.

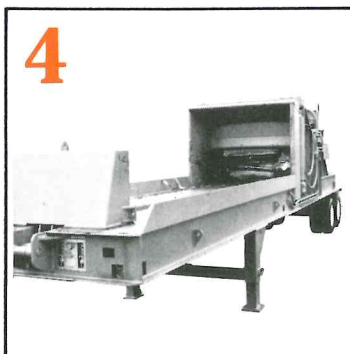
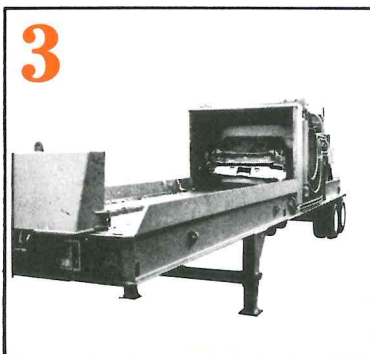
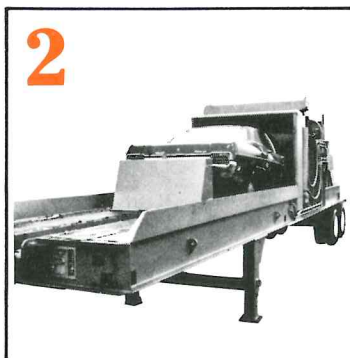
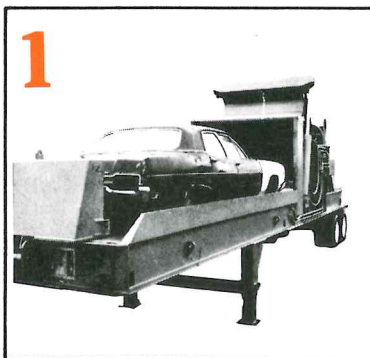

Process up to 200 cars a day without a crusher operator

The Al-Jon #20 uses over 350 tons of force to crush complete cars, with or without engines, into slabs approximately 10 inches high by 6.5 feet wide in less than 90 seconds. Automatic pressure relief protects the crusher from overloads. No operator is required for the crusher, the loader operator places a car on the conveyor section and presses the remote radio control.

The NEW dual button remote control allows the operator loader even more flexibility.



Greater loading flexibility increases crushing

The open 20-foot conveyor can be loaded by crane or from either side, allowing for efficient loading and efficient equipment. Load two conveyor loads. "Doubt increase daily output vehicles are fed easily." ed feature.

Now made even easier raised bridge.

Remote control and automatic cycling to reduce car crushing labor costs

The Al-Jon #20 Crusher minimizes labor so that you have better cost control over every car you send to the shredder. The Al-Jon does not require a crusher operator. The loader operator remotely activates the crusher while on the go. Just load, push a remote radio control and unload automatically crushed cars. The 350 tons of crushing force completely cycles in 60 to 90 seconds so that your loading equipment never stands idle. You'll get full payloads faster and each load means more profit because there's no wasted labor. Years of engineering experience and a dedicated parts/service department are additional reasons why Al-Jon has sold more crushers than any other company and why over 99 percent are still on the job today.

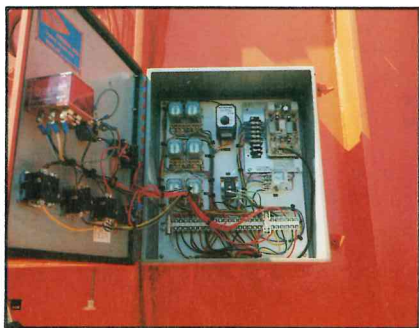
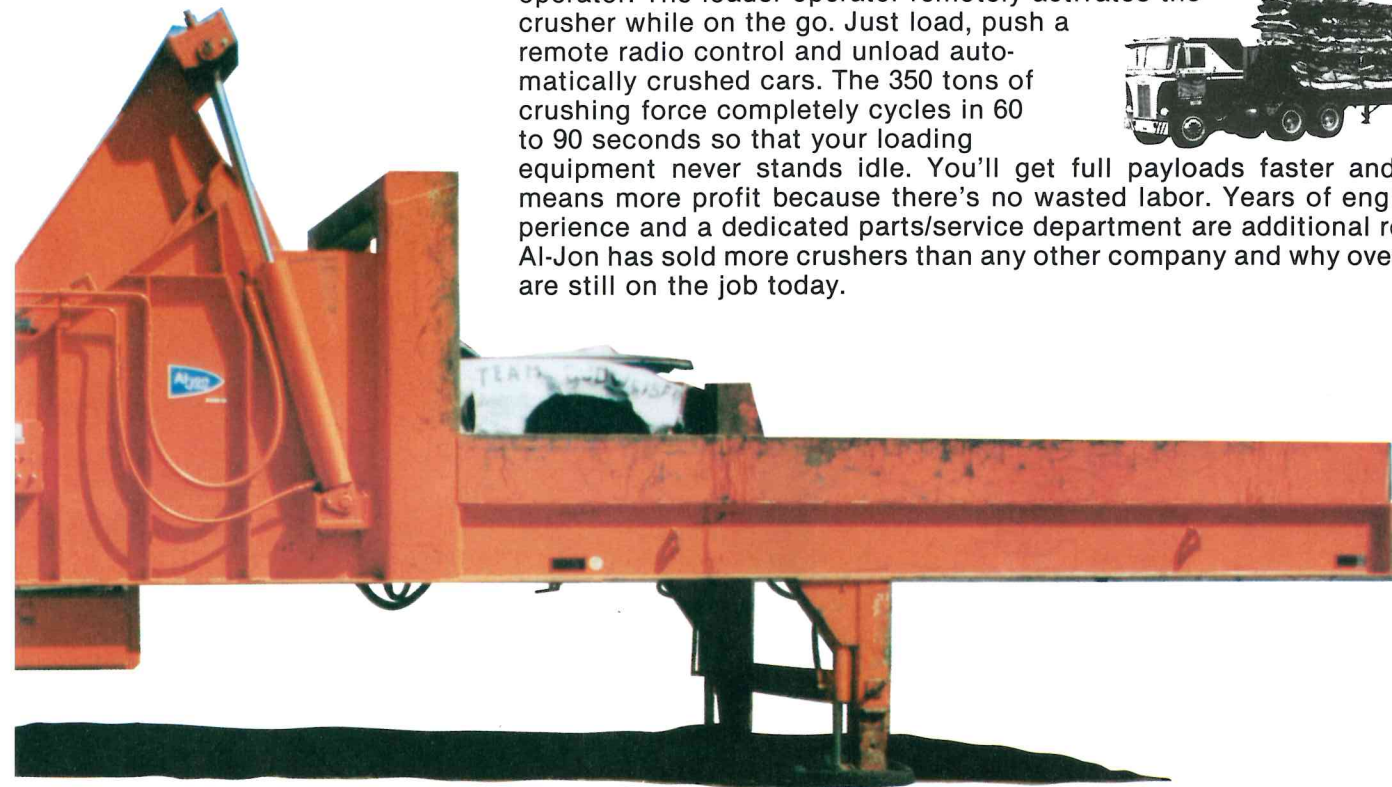

Flexibility output
 or section can
 ont-end loader
 g more flexible
 se of loading
 s on the same
 crushing" will
 ans and taller
 ith this improv-

Adjustable conveyor travel for shells and loose tin.
 Burnt and badly rusted cars, hulks minus frames and/or loose tin all can be crushed by the Al-Jon #20. Just flip a switch and conveyor travel length becomes preset to incrementally feed the car into the crushing chamber. Clean yards and satisfied customers are the key to Al-Jon's success.

Ruggedly built for continuous crushing
 Heavy-duty welded construction and simplicity of design are reasons why Al-Jon crushers are known for durability. The hydraulics are fully pressure protected and include as standard equipment strainers, filters and automatic dirt alarm. Both automatic and manual controls are provided as standard.

Legally transportable with no disassembly
 The #20 Crusher is fully road legal without special permits and is delivered to the customer with tandem axles, running lights, air brakes and hydraulic landing gear. The high ground clearance and low overall height avoid any moving problems. No disassembly is needed; just hook up, raise the landing gear and go. At the next site simply lower the hydraulic gear, unhook the tractor and start crushing.

with our newly

Reliability is now even better with our new permanently mounted solid state remote receiver.

High ground clearance.

6

profitable
reasons
to have an
Al-Jon #20
crusher
in your
scrap yard



OIL RECOVERY SYSTEM

Al-Jon's superior crushing abilities will crush all oil containing components. You can now turn a by-product into a profit with this new affordable system. Leaves the yard clean!



IMPROVED COMPONENT PROTECTION

Keeping Al-Jon's reputation for quality, we constantly look for ways to improve our product. Components such as the landing gear lever and the battery box have been relocated for better protection.

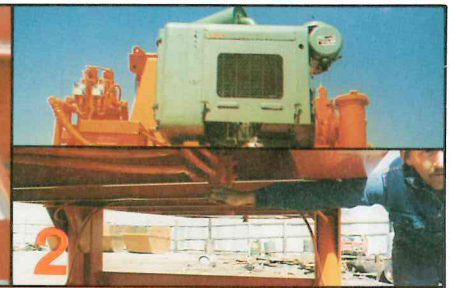

RAISED BRIDGE AND SIDES

Double crushing has never been easier! Process two cars at once. With Al-Jon you handle these cars only once, in addition to processing vans and taller vehicles.

Load it on the run and be assured the car will be processed in a clean flat package. No holding in doors! Al-Jon crushed cars go down the road tight, clean and well-stacked.



SOLID STATE REMOTE RECEIVER PERMANENTLY MOUNTED

The fastest set-up in the business is now even quicker. No longer must you connect the remote receiver — it's permanently mounted in the control box. So drop the landing gear and you're ready to crush!

DUAL BUTTON REMOTE CONTROL

Al-Jon's one man automatic operation is now even more efficient. One button still stops and starts the automatic cycling while the second button allows the operator to stop and/or retract the pusher block, all from the cab of the loader!



TIN CRUSHING OPTION

A very affordable package will allow you to process white goods, alley scrap, and various forms of loose tin. All in one machine!



1-800-Al-jon 20
Ottumwa, Iowa 52501 • P.O. Box 598