

[www.WhitakerBrothers.com](http://www.WhitakerBrothers.com)

Heavy Duty Granulators  
18"x37" and 20"x50"

Models Covered: B,  
GMB, HDG, MSH

Part Number: MAN-751972  
Bulletin Number: GRN2-600  
Effective: August 1, 2012



an **ACS** Group company



800-243-9226

Write Down Your Serial Numbers Here For Future Reference:

_____	_____
_____	_____
_____	_____

We are committed to a continuing program of product improvement.  
Specifications, appearance, and dimensions described in this manual are subject to change without notice.

DCN No. \_\_\_\_\_

© Copyright 2013

All rights reserved.

# Shipping Info

---

## ***Unpacking and Inspection***

You should inspect your granulator for possible shipping damage.

Thoroughly check the equipment for any damage that might have occurred in transit, such as broken or loose wiring and components, loose hardware and mounting screws, etc.

## ***In the Event of Shipping Damage***

According to the contract terms and conditions of the Carrier, the responsibility of the Shipper ends at the time and place of shipment.

Notify the transportation company's local agent if you discover damage.

Hold the damaged goods and packing material for the examining agent's inspection. **Do not return any goods before the transportation company's inspection and authorization.**

File a claim with the transportation company. Substantiate the claim by referring to the agent's report. A certified copy of our invoice is available upon request. The original Bill of Lading is attached to our original invoice. If the shipment was prepaid, write us for a receipted transportation bill.

Advise customer service regarding your wish for assistance and to obtain an RMA (return material authorization) number.

## ***If the Shipment is Not Complete***

Check the packing list as back-ordered items are noted on the packing list. You should have:

- Bill of lading
- Packing list
- Operating and Installation packet
- Electrical schematic and panel layout drawings
- Component instruction manuals

Re-inspect the container and packing material to see if you missed any smaller items during unpacking.

## ***If the Shipment is Not Correct***

If the shipment is not what you ordered, **contact the shipping department immediately**. For immediate assistance, please contact the correct facility located in the technical assistance section of this manual. Have the order number and item number available. *Hold the items until you receive shipping instructions.*

### **Returns**

Do not return any damaged or incorrect items until you receive shipping instructions from the shipping department.

### **Credit Returns**

Prior to the return of any material, **authorization** must be given by **the manufacturer**. A RMA number will be assigned for the equipment to be returned.

Reason for requesting the return must be given.

ALL returned material purchased from **the manufacturer** returned is subject to 15% (\$75.00 minimum) restocking charge.

ALL returns are to be shipped prepaid.

The invoice number and date or purchase order number and date must be supplied.

No credit will be issued for material that is not within the manufacturer's warranty period and/or in new and unused condition, suitable for resale.

### **Warranty Returns**

Prior to the return of any material, authorization must be given by **the manufacturer**. A RMA number will be assigned for the equipment to be returned.

Reason for requesting the return must be given.

All returns are to be shipped prepaid.

The invoice number and date or purchase order number and date must be supplied.

After inspecting the material, a replacement or credit will be given at **the manufacturer's** discretion. If the item is found to be defective in materials or workmanship, and it was manufactured by our company, purchased components are covered under their specific warranty terms.

# Table of Contents

---

<b>CHAPTER 1: SAFETY .....</b>	<b>7</b>
1-1 How to Use This Manual .....	7
<i>Safety Symbols Used in this Manual.....</i>	<i>7</i>
1-2 General Safety Regulations .....	10
1-3 Responsibility .....	10
1-4 Warnings and Precautions .....	11
<b>CHAPTER 2: FUNCTIONAL DESCRIPTION .....</b>	<b>13</b>
2-1 Models Covered in This Manual.....	13
2-2 General Description .....	13
2-3 Typical Features and Components .....	13
2-4 Safety Features .....	14
<b>CHAPTER 3: INSTALLATION.....</b>	<b>15</b>
3-1 Uncrating the Equipment.....	15
3-2 Belt Tensioning .....	15
3-3 Electrical Connections.....	15
3-4 Accessing the Cutting Chamber.....	16
3-5 Closing the Cutting Chamber .....	17
3-6 Initial Start-up .....	17
<b>CHAPTER 4: OPERATION.....</b>	<b>19</b>
4-1 Start-up and Operation.....	19
4-2 Feeding the Granulator .....	19
4-3 Clearing a jammed Cutting Chamber.....	19
4-4 Shut-down .....	20
<b>CHAPTER 5: MAINTENANCE .....</b>	<b>21</b>
5-1 Preventative Maintenance Schedule.....	21
5-2 Lubrication.....	21
5-3 Replacing and Adjusting the Knives.....	22
5-4 Sharpening the Knives .....	24
5-5 Adjusting Belt Tension .....	24
5-6 Rotor Bearing Replacement.....	27
<b>CHAPTER 6: TROUBLESHOOTING .....</b>	<b>28</b>
6-1 Introduction .....	28
6-2 Electrical Faults .....	28
6-3 Processing Faults.....	29
6-4 Mechanical Faults .....	30
<b>CHAPTER 7: APPENDIX.....</b>	<b>31</b>
7-1 Recommended Torque for Screws .....	31
7-2 Technical Specifications.....	31
7-3 Drawings .....	33
7-4 Recommended Spare Parts.....	34

7-5 Technical Assistance ..... 35  
    *Parts and Service Department* ..... 35  
    *Sales and Contracting Department* ..... 35

# Chapter 1: Safety

---

## 1-1 How to Use This Manual

Use this manual as a guide and reference for installing, operating, and maintaining your granulator. The purpose is to assist you in applying efficient, proven techniques that enhance equipment productivity.

This manual covers only light corrective maintenance. No other maintenance should be undertaken without first contacting a service engineer.

The Functional Description section outlines models covered, standard features, and safety features. Additional sections within the manual provide instructions for installation, pre-operational procedures, operation, preventive maintenance, and corrective maintenance.

The Installation chapter includes required data for receiving, unpacking, inspecting, and setup of the granulator. We can also provide the assistance of a factory-trained technician to help train your operator(s) for a nominal charge. This section includes instructions, checks, and adjustments that should be followed before commencing with operation of the granulator. These instructions are intended to supplement standard shop procedures performed at shift, daily, and weekly intervals.

The Operation chapter includes a description of electrical and mechanical controls, in addition to information for operating the granulator safely and efficiently.

The Maintenance chapter is intended to serve as a source of detailed assembly and disassembly instructions for those areas of the equipment requiring service. Preventive maintenance sections are included to ensure that your granulator provides excellent, long service.

The Troubleshooting chapter serves as a guide for identification of most common problems. Potential problems are listed, along with possible causes and related solutions.

The Appendix contains technical specifications, drawings, schematics, parts lists, and available options. A spare parts list with part numbers specific to your machine is provided with your shipping paperwork package. Refer to this section for a listing of spare parts for purchase. Have your serial number and model number ready when ordering.

### ***Safety Symbols Used in this Manual***

The following safety alert symbols are used to alert you to potential personal injury hazards. Obey all safety messages that follow these symbols to avoid possible injury or death.



***DANGER*** indicates an imminently hazardous situation that, if not avoided, will result in death or serious injury.







***WARNING*** indicates a potentially hazardous situation or practice that, if not avoided, could result in death or serious injury.









***CAUTION*** indicates a potentially hazardous situation or practice that, if not avoided, may result in minor or moderate injury or in property damage.

**Figure 1: Safety Tags and warning features**

Hazard Alert Symbol	Description/Explanation	Preventative Maintenance
	<p>High Voltage Hazard. The electrical enclosure is supplied with 3-phase electrical power. Use caution when using or maintaining this product.</p>	<p>Every six months inspect all electrical connections for secure attachment. For further information see the Maintenance Chapter in this manual</p>
	<p>Hands could be exposed to a crushing movement.</p>	<p>Every month inspect the shears/blades for any type of wear. For further information see the Maintenance Chapter in this manual.</p>
	<p>When equipped with belts and sheaves, hands could become entangled.</p>	<p>Every month inspect the belt(s) for any type of wear. For further information see the Maintenance Chapter in this manual.</p>
	<p>Hands can become entangled or cut if they enter the danger zone of gears or cutting shears.</p>	<p>Every month inspect the shears/blades for any type of wear. For further information see the Maintenance Chapter in this manual.</p>
	<p>The unit can produce continuous noise above 85 dBA and/or produce projectiles under normal operating conditions.</p>	<p>Always wear eye and ear protection when the machine is in operation or performing maintenance.</p>



Mandatory Symbol	Description/Explanation
	<p>Read Operators Manual. This equipment must be operated and maintained by properly trained personnel. The information contained within this manual must be read and understood prior to operating this equipment.</p>
	<p>Lock Out. This equipment is operated with 3-phase electrical power. Therefore, when performing any maintenance operations we recommend following the local standards for performing a lock-out/tag-out procedure.</p>
	<p>Wear Safety Gloves. This equipment operates with sharp blades and rotors. We recommend that technicians use safety gloves while performing maintenance to protect hands from being exposed to these sharp surfaces.</p>
	<p>Wear ear and eye protection. This unit may produce loud and continuous noise and may produce projectiles.</p>
	<p>Pneumatic or hydraulic equipment. Pneumatic or hydraulic equipment must be kept at a safe pressure.</p>
	<p>Do not reach into unit. Reaching into a unit is prohibited while the unit is in operation and may cause serious injury.</p>

## 1-2 General Safety Regulations

This machine uses knives for the performance of its intended use. Consequently, it can be a dangerous machine to operate and maintain unless these safety regulations are followed.

These regulations should be read, understood and periodically reviewed by all personnel involved in any way with this machine.

Never operate or remove any machine components that are secured by wrench-type fasteners unless the motor is electrically locked out and the rotor is motionless.

Never operate the machine or jog the rotor unless the cutting chamber covers, discharge chute, or any guards or covers are in place and secure. Do not circumvent the safety interlocks.

Prior to clearing a jam or performing any maintenance, the motor should be turned off and electrically locked out. Be sure that the rotor has come to a stop. Hands must not be inserted into the machine to clear the jam.

Do not extend any part of the body into feed roll openings or discharge area unless the motors are electrically locked out and the rotor and feed rolls are motionless.

Never extend fingers through holes in screen.

Be sure that the v-belts are properly aligned and that tension is at its maximum.

Extreme care should be taken to see that all bolts are properly tightened at all times. During the operation of the machine, rotor knife bolts may come loose. Although fine threads are used on the rotor knife bolts because vibration does not easily loosen them, you should inspect the tightness of the bolts frequently.

This machine is designed for the granulation of plastic materials. Do not feed any other materials into the machine.

## 1-3 Responsibility

These machines are constructed for maximum operator safety when used under standard operating conditions and when recommended instructions are followed in the maintenance and operation of the machine.

All personnel engaged in the use of the machine should become familiar with its operation as described in this manual.

Proper operation of the machine promotes safety for the operator and all workers in its vicinity.

Becoming familiar with materials, inspection, speed limitations, screens, and guard maintenance and total user responsibility will assist you in learning potential areas in need of observation for danger.

Each individual must take responsibility for observing the prescribed safety rules as outlined. All caution, warning and danger signs must be observed and obeyed. All actual or potential danger areas must be reported to your immediate supervisor.

## 1-4 Warnings and Precautions

Our granulators are designed to provide safe and reliable operation when installed and operated within design specifications, following national and local safety codes.

To avoid possible personal injury or equipment damage when installing, operating, or maintaining this granulator, use good judgment and follow these safe practices:

- ␣ **LEARN AND OBEY** your company's safety policy regarding granulating equipment.
- ␣ **MOVING OR LIFTING THE GRANULATOR:** Although our equipment is built and engineered for great ruggedness in operation, care must be taken when moving the machine along the floor or lifting it. Damage may occur to sheet metal covers, electrical cabinets, or small brackets if pressure is applied to them when moving the granulator. When lifting the granulator, be certain of total machine weight and the capability of the lifting equipment. (See the Granulator Specification Sheets for machine weights and dimensions.)
- ␣ **GRANULATOR LOCATION:** Adequate area for routine maintenance should be provided in order to open the machine for knife, screen, or cleanout service. Proper service area clearances also should allow people who are working on the machine to be clearly visible to others, thereby reducing the potential safety hazards.
- ␣ **SAFE HOUSEKEEPING:** The work area must be kept clean and uncluttered during periods of operation or maintenance. No hand tools or other metal objects should be left on or around the machine. Any tools or other metal objects that mistakenly fall into the hopper feed opening can cause severe damage to internal cutting chamber, rotor and screen components.
- ␣ **SAFETY GLASSES OR A FACE SHIELD MUST ALWAYS BE WORN** when servicing or operating the machine. Although our machines are designed for the maximum in fly back control, caution must be used when operating near the hopper feed opening in order to guard against unexpected material fly back.
- ␣ **EAR PROTECTION** may be required when operating the machine during granulation of very hard or noisy materials. The Occupational Safety and Health Act of 1970 has established guidelines for Permissible Noise Exposures (OSHA 1910.95) that should be followed.
- ␣ **NEVER** attempt to operate the granulator unless it is fully assembled with all guards and interlocks in place and functional.
- ␣ **OBSERVE** all danger, warning, caution and safety labels on the equipment.
- ␣ Upon completion of any machine maintenance, be certain **ALL SAFETY GUARDS AND COVERS** are securely and properly fastened prior to resuming machine operation. All fasteners must be in place and properly tightened. **ANY SHORTCUTS MAY RESULT IN INJURY TO PERSONNEL OR DAMAGE TO EQUIPMENT.**
- ␣ **NEVER** wear any loose fitting clothes, neckties, wrist watches, or dangling items such as earrings, belts, or shoestrings. Jewelry, such as wristwatches, bracelets, or rings should **NEVER** be worn. Long hair must be tied back or placed in a tight fitting hairnet. **NEVER** lean against or rest hands or feet on the granulator when it is in operation or open for maintenance. **NEVER** stand on the granulator when it is in operation.

- ␣ **ROTATION OF MOTORS:** The correct rotating direction for the granulator motor is clearly marked on the machine. Always check for proper rotation of motors. Incorrect rotation direction can cause severe damage.
- ␣ **ELECTRICAL GROUNDING:** All electrical equipment on the granulator must be grounded in accordance to all local codes and Article 250 of the National Electric Code.
- ␣ **ALWAYS DISCONNECT AND LOCKOUT** the main electrical power to the granulator before performing any service.
- ␣ **SAFETY INTERLOCKS MUST NOT BE BYPASSED.** The mechanical and electrical safety interlocks ensure the safety of personnel. They should never be tampered with or removed for ANY reason. They should be checked frequently by a qualified mechanic for proper operation.
- ␣ **NEVER** modify the machine configuration or any individual component without written notice from the factory.

For further information on granulator safety, installation and operation, see the *American National Standard for Plastics Machinery-Granulators, Pelletizers, and Dicers Used for Size Reduction of Plastics-Construction, Care, and Use*. ANSI B 151.11-1982.

We have long recognized the importance of safety and have designed and manufactured our equipment with operator safety as a prime consideration. We expect you, as a user, to abide by the foregoing recommendations in order to make operator safety a reality

# Chapter 2: Functional Description

---

## 2-1 Models Covered in This Manual

This manual provides the necessary instruction for the installation, setup and maintenance of our 18"x37" and 20"x50" models and includes models: B, GMB, HDG, MSH

## 2-2 General Description

This granulator is a rugged, rotary-cutting machine specifically designed to cut, chip, and granulate the toughest plastic materials with a minimum expenditure of horsepower.

Heavy-Duty granulators feature a massively built, low RPM high inertia rotor with chevron knives, accepts large parts and assures long, trouble-free service.

The hopper is designed to remain stationary to allow for a smaller footprint and the screen to pull out from the side for quick access into the cutting chamber.

These granulators are ideal for pipe, purgings, X-ray film, psi-consumer baled bottles, film and fibers.

## 2-3 Typical Features and Components

### *Hopper*

The hopper is an upright enclosure bolted to the top of the cutting chamber. The hopper is designed to facilitate feeding of material to the rotary knives and to prevent chips thrown from the cutting chamber from reaching the operator.

### *Cutting Chamber*

The cutting chamber is a rectangular enclosure comprising the main frame, the bed knives, the bed knife shields, a balanced rotor and a screen.

The main frame of the cutting chamber carries the bed knives and the bed knife shields. The downstroke bed knife shield is adjustable.

The screen is supported in position below rotor and acts as a separating barrier to the granulated material, retaining the material in the cutting chamber until the particle size is such that it will pass through the screen holes.

The rotor carries the rotor knives. The rotation of the rotor produces a cutting action between the rotor and the stationary bed knives, thus reducing the material size.

### *Drive System*

The rotor is indirectly driven by the motor through v-belts. The motor shaft pulley, v-belts, and the rotor shaft pulley are shielded by safety guards or sound enclosure.

The motor is mounted on an adjustable sliding base, which is mounted at the left end of the granulator

### ***Discharge System***

The granulated material that falls through the screen is collected by the customer's Gaylord box.

On models fitted with an airveying system (optional), the granulated material that has fallen through the screen is collected in a transition piece located beneath the cutting chamber. The transition piece is connected to a blower, which conveys the granulated material to drop out of the air system into a container.

### ***Base***

The base is a floor mounted drum and Gaylord type supporting the cutting chamber on its top surface and the Gaylord chute from below the top surface. This base should be fastened securely to the surface beneath it.

## **2-4 Safety Features**

### ***Motor Starter***

A magnetic motor starter with control transformer must be used when safety switches are installed. Manual starters should not be used under any conditions.

### ***Safety Switches***

Safety switches at all access covers are wired into the starter control circuit. The machine cannot be started when these parts are open. However, for safety purposes, the machine should be disconnected from the power lines by a disconnect switch or by removing the plug from its receptacle. Check all safety switches periodically for proper operation.

### ***Safety Tags***

A set of metal plates is attached to the machine to warn of potential danger.

### ***Brake Motors (Optional)***

An integral brake stops the motor within a few seconds of actuation of the stop button, greatly reducing the time required for the rotor to stop.

### ***Sound Reduction Equipment***

Sound reduction equipment will bring the sound level of your machine to within the limitations of the Occupational Safety and Health Act. Material, part configuration, feed rate and ambient noise level must be specified at the time of inquiry.

# Chapter 3: Installation

---

## 3-1 Uncrating the Equipment

The complete granulator, including accessory and auxiliary equipment, is skidded for shipment. Refer to the Appendix for detailed dimensional data and pertinent weights. Prepare in advance the site you have selected for installation of the granulator. Be certain that the area to be occupied by the machine is clean, level and free of obstructions. The machine should be set on a concrete floor, and care must be taken when moving the machine across a hollow timber floor, so that the point loading of the casters does not cause damage. The site you have selected must have a floor rating to adequately support the weight of the machine. If necessary, use steel shims to level the machine.

Locate the machine so that access is given to electrical components, screen and hopper. Maintenance personnel should have unobstructed access to the units on which they will be working.

To avoid squeezing people working near a machine, there should be adequate clearance maintained between machines, walls, or partitions. Hinged doors and covers should have full swing. Restrictions may force work in cramped quarters. An off-balance operator with an awkward reach into a partially obscured area is unsafe.

If inspection after shipment has revealed no shipping damage, unpack the unit by removing all hold-downs, tie-downs, bolts, nuts, etc. Remove the envelope with the electrical schematics and instruction manual from the base evacuation area.

You can now have the machine lifted from the skid. To lift and move the granulator safely and correctly, cover any sharp corners or edges, and use the type of equipment that has the most appropriate features and capacity. Use the designated lifting point, and **DO NOT** lift the machine by the hopper handles or guards.

### CAUTION

*Because of the size and weight of the granulator, we recommend that only qualified riggers be employed to unpack and locate the granulator.*

## 3-2 Belt Tensioning

Tension the belts at the maximum recommended force. Check the tension at least twice during the first day of operation. See Section 5-5 on page 24 for the belt tensioning procedure.

## 3-3 Electrical Connections

Granulator controls (if ordered) are shipped separately for mounting at a suitable location. The safety switches are connected to a common terminal box for ease of wiring. The customer is required to provide a suitable fused supply with a disconnect switch and a cable for the incoming line to the starter.

Refer to the technical specifications in the Appendix for horsepower, voltage, phase and frequency requirements to determine the size and rating of the supply cable required.

If optional controls are required, an electrical wiring diagram will be provided with the machine in addition to the basic electrical diagram.

When the customer is providing either the motor or the starter, the machine must be wired in accordance with the basic electrical diagram and the starter manufacturer's instructions.

Use the following procedure to complete the electrical connections:

1. Check to be certain that the starter heater elements correspond with the motor requirements. If controls are not supplied, the limit switches supplied on the machine must be wired into the circuit at the common terminal box.
2. Check that the limit switches are closed.
3. Turn switch ON at main power supply.
4. Jog motor by pressing the START and then the OFF button. This starts and stops the motor.
5. With the electrical power ON, check that the motor rotates in a clockwise direction at the viewing port in the belt guard. If motor rotation is correct, continue to the next step. If rotation is incorrect, complete the following procedure:
  - a. Shut power OFF and disconnect incoming power supply.
  - b. Reverse any two of the three power line connections to the machine.
  - c. Re-connect the incoming power supply line and turn ON the main power switch to recheck motor drive rotation.
6. If Airveying system (optional) is fitted, press the Airveyor START button and check the blower motor rotation. The blower motor should rotate in a counter clockwise direction. If blower motor rotation is correct, continue to step 7. If blower motor rotation is incorrect, complete the following procedure:
  - a. Shut power OFF and disconnect incoming power supply line.
  - b. Reverse any two of the three power connections to the blower motor.
  - c. Re-connect the incoming power supply line and recheck the blower motor rotation.
7. Allow all motors to run up to speed for at least 30 seconds.

### 3-4 Accessing the Cutting Chamber

You will need to access the cutting chamber before initial startup and for various maintenance procedures. Use the following procedure to access the cutting chamber:

1. Turn main power off, remove the line fuses and tag the machine as out of service.
2. Remove the hex head bolts along the top of the cutting chamber covers.
3. Swing the covers downward using the handles that are provided on each cover. Do not allow the covers to drop freely of their own weight.
4. Remove the two screws holding the screen closure on the end of the machine opposite the drive, and remove the screen through the curved slot in the end plate.



*NOTE: It may be necessary to back out the screens that hold the screen down on the screen supports, along the sides of the machine*



### 3-5 Closing the Cutting Chamber

After completing any maintenance or adjustments inside the cutting chamber, use the following procedures to close the cutting chamber and resume use of the granulator:

1. Replace the screen and the screws holding the screen closure on the end of the machine.
2. Swing the cutting chamber doors back into their closed position and replace bolts.
3. Rotate the rotor by hand from outside the machine to check that no tools, gauges, or loose parts have been left on or in the machine.
4. Replace line fuses, turn power on, and remove the “Out of Service” tag from the machine.



### 3-6 Initial Start-up

This machine has been run under power and tested at the factory prior to shipment. The necessary settings and adjustments have been made so that a minimum amount of setting up or re-adjustment is required when starting up the machine in its new location.

With all electrical, mechanical connections and lubrication requirements having been attended to, the following start-up steps should be carefully carried out before attempting to place any material into the infeed hopper. Use the following procedure to prepare the machine for initial start-up.

#### **WARNING**

*Before operating the granulator, insure that the granulator has been correctly assembled and wired.*

1. Access the cutting chamber as described in Section 3-4 on page 16.
2. Thoroughly clean the rust preventative materials or grease from the inside of the cutting chamber and screen.
3. Check all rotor knives to make sure they are properly seated on the rotor and securely fastened. Although they are ground as set, one knife will probably be .001” to .002” higher than the others. This should be marked and used when adjusting the bed knives for proper clearance.
4. Use a feeler gauge to check the clearance between the rotor and bed knives by turning the rotor backwards. Rotating the rotor backwards gives a better feel and does

not cut the gauge, should the knives be too close. Check the knives on each end only. Proper clearance is 0.005” to 0.008” for most materials. 0.014” to 0.016” for solid wall pipe with 0.187” wall thickness or greater. This clearance is slightly greater at the center of the knives.

***Note: Recheck knife clearance after the first 24 to 36 hours of operation.***

5. To make the adjustment on the bed knives, the bed knife bolts should be hand tightened to hold the knife firmly against the knife seat while adjusting the knife forward using push and pull screws. After the clearance is set, torque the screws according to Section 7-2 on page 30.
6. With the exposed parts of the machine thoroughly clean, and all knife clamping bolts securely fastened, close the cutting chamber as described in Section 3-5 on page 15.

***Note: After initial start-up, the rotor knife retaining screws should be checked after 8 hours running to be assured that the proper torque is maintained. Thereafter, rotor knife retaining screws should be checked weekly.***

***Note: The rotor must be rotated at least two rotations every 30 days to prevent brinnelling and corrosion of raceways.***

# Chapter 4: Operation

## 4-1 Start-up and Operation

Before starting the machine, check that the rotor rotates freely by rotating it by hand from outside the machine using either the coupling or the sheave depending on the type of drive. Inspect the cutting chamber carefully to insure that nothing has fallen into it. Make sure all screws and bolts are properly secured. Check all electrical connections and motor rotations. See Chapter 3 on pages 14-17 for detailed start-up instructions. Allow all motors to run up to speed for at least 30 seconds.

## 4-2 Feeding the Granulator

Feed the granulator through the opening in the hopper. The method of feeding the granulator depends on the physical form and nature of the material being processed.

For maximum efficiency, the granulator should be fed at a rate that is consistent with its capacity; i.e., if the granulator is rated at 3,000 lbs./hr. (1360 kgs./hr.), then the general feed rate is 50 lbs./min (23 kgs./min). Under these operating conditions, the correct proportions of cut and uncut particles will be present in the cutting chamber.

*Under no circumstances should the operator attempt to reach into the hopper to dislodge any bridge or jammed material while the granulator is in operation. To clear the hopper of bridged or jammed material, the machine main power must be turned off and the machine isolated.*

**WARNING**



## 4-3 Clearing a jammed Cutting Chamber

Never attempt to free a jammed machine by placing hand on the rotor, rotor knives, or inside the cutting chamber. Hands must be kept clear of the rotational path of the rotor knives.

Good footing on a clean floor is essential and the body should be well braced to guard against loss of balance should the jam suddenly come free. Use the following procedure to clear a jammed cutting chamber.

1. Disconnect and lock out power.
2. Be certain that the rotor is motionless.
3. Open the machine as instructed in Section 3-4 on page 15.
4. Use a pry bar to exert force on the rotor, usually in the direction opposite normal rotation. A leather mallet and a block of wood of sufficient length to keep hands away from path of knives can be used if necessary.
5. Use pliers to remove material from the cutting chamber, keeping in mind that the removal of material may cause rotation of the rotor and rotor knives.
6. After cleaning the jam, be certain that the screen and all guards and covers are secured in place before connecting power and starting the machine.

## 4-4 Shut-down

Use the following procedure to properly and safely shut down the machine:

1. Stop all feeding of material
2. Allow the granulator to run until the cutting chamber is completely empty.
3. Press the drive motor “stop” button. This shuts off the rotor drive motor.
4. After the granulator has stopped, press the airveyor stop button (if applicable) located at the blower motor.
5. Turn the main power switch to off.

# Chapter 5: Maintenance

## 5-1 Preventative Maintenance Schedule

Check	Frequency
Knife clearance	Weekly
Knife retaining screws for tightness	Weekly
Knife exposure	Weekly
Shield retaining screws for tightness	Weekly
Screen retaining studs fro tightness	Weekly
Lubrication of drive motor bearings	Monthly
Lubrication of rotor bearings	Monthly
Screen Wear	Monthly
Belt Tension	Monthly
Hopper and cutting chamber screws are tight	Monthly

## 5-2 Lubrication

Lubrication of rotor bearings should be based on the size and type of bearing, the RPM at which the rotor is turning, and the temperature at which the bearing is operating.

The size of the bearing will determine the amount of grease required. The RPM, bearing type, and size of the bearing will determine the frequency of lubrication. Higher than normal temperatures will determine the amount of grease required.

### *New Bearings*

Bearings are initially lubricated at the factory prior to shipment. However, when assembling new bearings and before bearing caps are installed, fill every third cavity of the bearing using a hand grease gun, and then rotate the shaft by hand to distribute the grease. Fill the bearing cavity 1/3 full of grease.

A hand-operated grease gun is preferred over a power grease gun because of better control of pressure and quantity dispensed. This tends to prevent over-greasing and damage to seals.

Run the machine and observe drainage from the bearing housing. If a soupy discharge is observed (indicating oil separation), then add a couple of sots of grease from a hand gun at intervals until the discharge is no longer soupy.

### *Re-Lubrication*

A new granulator rotor bearing should be greased after the first two weeks of operation, and then re-lubricated every 2-4 weeks, depending on the duty cycle. Continuous operation (24 hours a day) at a maximum capacity would require lubrication every 2 weeks. Intermittent operation and/or light duty intervals could require lubrication every 4 weeks.

The period during which a grease-lubricated bearing will function satisfactorily without re-lubrication depends on the bearing type, size, speed, operating temperature, and the grease used. Re-lubrication intervals (hours of operation) are valid for bearings in machines where loading conditions are normal: an age-resistant, average quality grease is used and the operating temperature is below 158°F (70°C) measured at the outer ring.

Re-lubrication intervals should be halved for every 27°F (15°C) increase in the temperature above 158°F (70°C). The maximum permissible operating temperature for the grease must not be exceeded.

**Note:** *Re-lubrication intervals may vary significantly even where apparently similar greases are used.*

Where there is a high risk of the grease becoming contaminated, the re-lubrication frequency should be increased. This reduction also applies to applications where the grease is required to protect against moisture. These bearings should be re-lubricated once a week.

We recommend using 2-4 ounces of grease when re-lubricating. Recommended grease are Sun Presitge #741EP or Mobilux EP2.

### 5-3 Replacing and Adjusting the Knives

During use, the clearance between the rotor knives and the bed knives will increase due to wear. This is a normal condition that requires re-setting this clearance once or twice before it is necessary to remove the knives for regrinding. Check the knives weekly for wear, clearance, exposure and screw tightness.

When new knives are fitted to the machine, adjustment after eight hours of running time may be required.

Before assembling a new or reground set of knives, make sure the knife seats and mounting holes are clean. Do not use grease or oil on screws or tapped holes when assembling the knives.

Knives must be replaced in complete sets; otherwise it will not be possible to obtain even clearance between the rotor knives and bed knives.

***Before applying a wrench to any knife bolt, be certain that the rotor is blocked to prevent rotation. One such method is to use a block of wood at least 1 1/2" thick between a knife and a fixed portion of the frame.***



#### **Rotor Knives**

We recommend that the rotor knife screws be replaced with new screws every sixth knife change to reduce the risk of screw failure due to overstretching. Screws must be replaced with the type specified in the spare parts list. Use the procedure to replace or adjust the rotor knives.



***Rotor knives should be changed one seat at a time to prevent rotor from being rotated in and out-of-balance condition.***

1. Access the cutting chamber as directed in Section 3-4 on page 15.
2. Loosen check nuts on bed knife adjusting screws and back off screws
3. Remove bed knife shields.
4. Disengage bed knife pull screws
5. Remove the bed knife bolts and bed knives.

6. Remove rotor knife bolts and knives on one seat. This should be done from the downstroke side of the cutting chamber.
7. Thoroughly clean knife set.
8. Install new knife on seat and tighten knife bolts. See Section 7-2 on page 30 for torque recommendations.  
Note: Bolt threads should be oiled. Wipe thread with an oil-dampened cloth.
9. Repeat steps 6 through 8 for each rotor knife.

### ***Bed Knives***

We recommend that the same screws and washers be re-used only when the bed knives have been repositions or re-ground. When blunt knives are discarded and replaced with new knives, use new screws and washers. This will reduce the risk of screw failure due to their overstretching. Screws and washers must be replaced with the type specified in the Spare Parts List. Use the following procedure to replace or adjust the bed knives:

1. Access the cutting chamber as directed in Section 3-4 on page 15.
2. Loosen the check nuts on the bed knife adjusting screws and back off screws.
3. Remove the bed knife shields.
4. Disengage the bed knife pull screws.
5. Remove the bed knife bolts and bed knives.
6. Before installing and adjusting the bed knives, check all rotor knives to make sure they are properly seated on the rotor and securely fastened.
7. Place the downstroke bed knife and its shield in place and hand-tighten the knife bolts to hold them firmly to the knife seats.
8. Using the push and pull screws to set the knife clearance to 0.005" to 0.008" for most materials; 0.014" to 0.016" for solid wall pipe with 0.187" wall thickness or greater. The clearance should be measured with a feeler gauge at the ends of the knife, by rotating the rotor sheave backwards by hand. The clearance is slightly greater at the center of the knives.
9. Adjust the shield using its push and pull screws so that its front edge is within 1/16" of the bed knife edges.
10. Tighten all bolts using the recommended torque values in Section 7-2 on page 30.
11. Repeat steps 7 through 10 for the upstroke bed knives.

## 5-4 Sharpening the Knives

Under normal operating use, the cutting edge of the knives will eventually become dulled, resulting in reduced cutting efficiency. The blunt knives may either be re-ground to restore the cutting edge, or replaced with new knives with regrinding is not possible.

When sharpening, it is not harmful to allow a few small nicks to remain in the cutting edge. Grinding the cutting edge until perfectly clean can sometimes be wasteful.

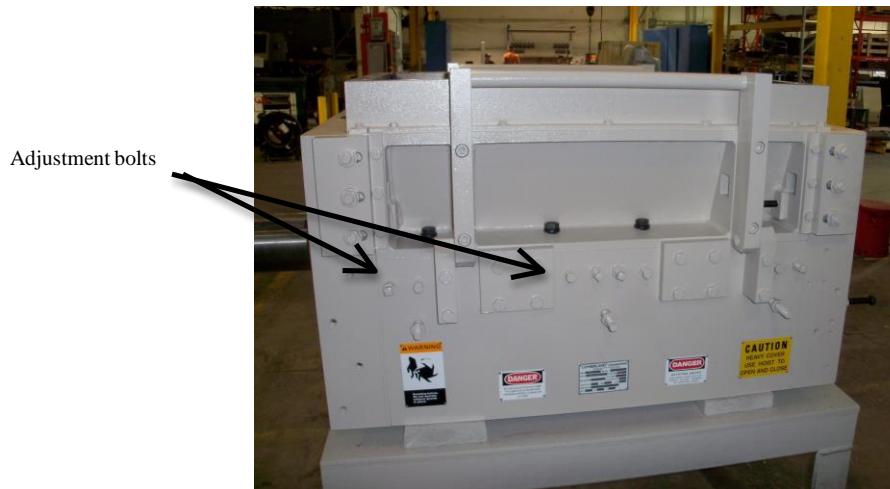

## 5-5 Adjusting Belt Tension

For continuous reliable operation of the granulator, it is important that the belt tension is correct. Correct tension reduces wear on rotor and motor bearings and keeps belt slip to a minimum. Figure 2 gives the recommended force to deflect each belt by an amount equal to the belt span divided by 64. A gauge is available through the sales department to measure the deflection and force. Use the following procedure to adjust the belt tension:

1. Turn off the granulator at the main isolator switch and remove fuses.
2. Remove the cover to gain access to the belts.
3. Turn the adjusting screw on the motor slide base to tension the belts as required (See Figure 2)
4. Re-tighten the screws, making sure the pulleys are in correct alignment.
5. Replace the covers.

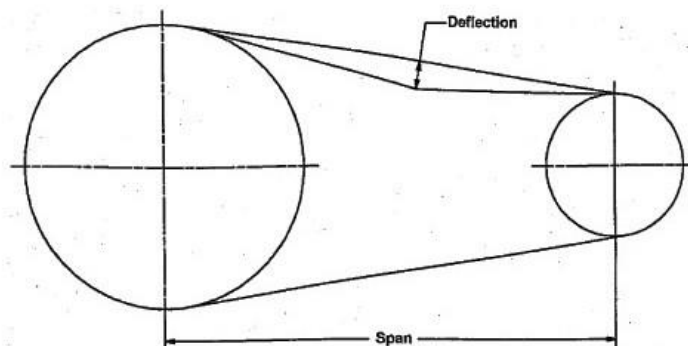



1. Verify that the alignment of the pulley is correct. Utilizing a straightedge of sufficient length to span from one pulley to the other, place it along the sides of both pulleys. The entire face of each pulley should fully contact the straightedge.
2. Measure the belt **SPAN** with a measuring tape. Record this dimension in your note book.
3. Using the deflection tester, apply a perpendicular force at the midpoint of any one of the belts to deflect the belt 1/64th of an inch.
4. Calculate the deflection force:  
$$\text{FORCE[Lb]} = \text{SPAN[IN]} \times (1/64)[\text{Lb/IN}]$$
5. Identify the belt type and measure the small sheave diameter. Look up the proper model belt deflection force table and find out what the force is supposed to be.
6. The motor position should be adjusted until the actual deflection force matches the force listed in the table.

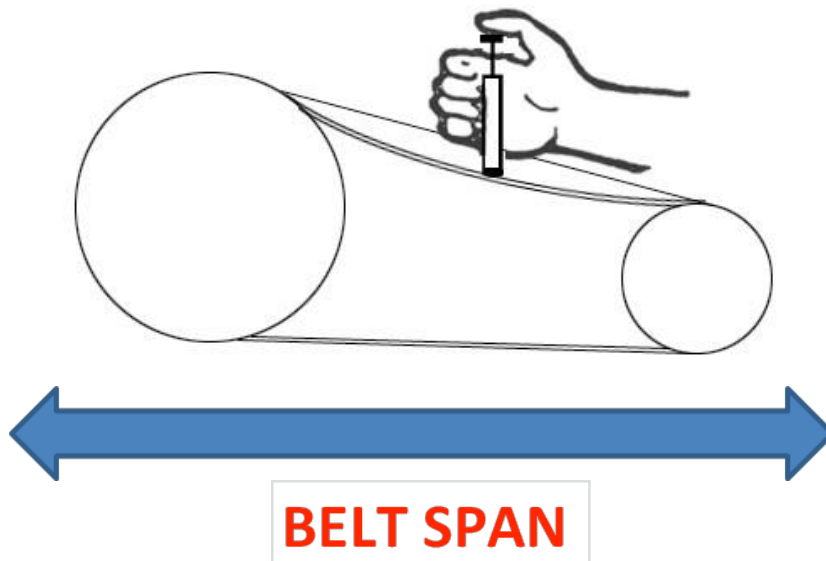

**⚠ CAUTION**

7. In no case should the belts be over tensioned, as this can significantly reduce belt and/or bearing life

Figure 2: Belt Tensioning Information

BELT	SMALL SHEAVE DIA.	DEFLECTION FORCE: LBS.			STEEL CABLE GRIPBELTS
		STANDARD GRIPBELTS	SUPER GRIPBELTS	GRIPNOTCH BELTS	

BELT CROSS SECTION	SMALL O.D. RANGE	DEFLECTION FORCE: Lbs
3V	2.65-3.65	5
	4.12-6.9	6.9
5V	7.1-10.9	16
	11.8-16.0	20
8V	12.5-17.0	41
	18.0-22.4	45

## 5-6 Rotor Bearing Replacement

Use the following procedure to remove and replace the rotor bearings:

1. Shut off the machine and the main power disconnect.
2. Remove the flywheel guard and drive belts
3. Loosen the flywheel sheave bushings and bolts, and remove the shaft end cap. Remove the flywheel and bushing. Loosen bolts on the bearing end cap and sheave spacer.
4. Clean grease and dirt from the bearing's exposed surfaces and shaft surfaces.
5. Remove the bearing housing containing the bearing from the shaft using the symmetrical pattern for push screws in the bearing housings.
6. Note the condition of the shaft journal and clean and dress the surface to remove all irregularities before installing the new bearing.
7. Replace the bearing housing in its correct position and tighten the  $\frac{3}{4}$  - 16 bolts to 400 ft. lbs.
8. Clean the bearing bore surface and the shaft journal.
9. Install the bearing on the shaft journal by lightly tapping the inner race in a uniform fashion until it bottoms out on the bearing housing seat.
10. Pack grease between the bearing rollers and re-install the sheave spacer and bearing end cap. Tighten the  $\frac{1}{2}$ -20 bolts to 58 ft. lbs.
11. Replace the flywheel/sheave bushing without tightening the bushing bolts. Replace the shaft end plate and tighten the 5/8-18 bolts to 144 ft. lbs. so that the flywheel bushing and sheave spacer are locking the bearing inner race to the shaft shoulder.
12. Tighten the sheave bushing to the flywheel/sheave. Replace and adjust the belts. Replace the covers.

# Chapter 6: Troubleshooting

## 6-1 Introduction

The utmost in safety precautions should be observed at all times when working on or around the machine and the electrical components. All normal trouble-shooting must be accomplished with the power off, line fuses removed, and with the machine tagged as out of service.

The use of good quality test equipment cannot be over-emphasized when troubleshooting is indicated. Use a good ammeter that can measure at least twice the AC and DC current that can be encountered for the machine. Be sure that the voltmeter has at least minimum impedance of 5,000 OHMS-per-volt on AC and 20,000 OHMS-per-volt on DC scales. Popular combination meters, VOM and VTVM can be selected to provide the necessary functions.

Before making haphazard substitutions and repairs when defective electrical components are malfunctioning, we recommend that you check the associated circuitry and assemblies for other defective devices. It is common to replace the obviously damaged component without actually locating the real cause of the trouble. Such hasty substitutions will only destroy the new component. Refer to wiring diagrams and schematics.

Locating mechanical problems, should they occur, is relatively straightforward. When necessary, refer to the parts catalog section.

## 6-2 Electrical Faults

Problem	Possible Cause	Possible Remedy
Motor fails to start	Supply failure	Check fuses
	Starter inoperative	Check main supply
	Starter overloads or cuts out	Check motor requirements and adjust accordingly
	Safety switches inoperative	Check and adjust as needed
Motor starts but will not take load	Too much belt tension	Check belt tension and adjust as necessary
	Incorrectly connected motor	Check terminal connection with manufacturer's connection diagram and adjust as necessary
	Defective starter winding	Check current in each phase with ammeter, if there is a marked difference in current in one phase, contact motor manufacturer
Motor will start when disconnected from load but not when connected	Worn bearings	Check and replace if necessary according to manufacturer's literature

## 6-3 Processing Faults

<b>Problem</b>	<b>Possible Cause</b>	<b>Possible Remedy</b>
Stalling	Overfeeding	Reduce feed rate
	Partial or complete screen blockage	Remove screen, clear and inspect for damage
	Insufficient tension on v-belt drive causing belt slip and burning	Check tension of the belt and adjust as necessary
	Badly blunted or damaged knives	Fit re-sharpened or new knives as required
	Knife setting too wide	Check clearances given and adjust as required
	Installation fault; motor running in reverse direction	Check with direction arrow and re-fit electrical connections to give the correct direction
	Safety switch cut out where fitted	Tighten safety switch setting screw
Material overheating	Check all possible causes under "stalling"	Remedy as shown above
	Screen size too small	Increase screen size
	When granulating rubber, insufficient talc causes freshly cut surfaces to re-adhere	Increase talc percentage rate of infeed
	Blockage in airveyor	Check direction of fan rotation, check venture and line or chute for blockage

## 6-4 Mechanical Faults

Problem	Possible Cause	Possible Remedy
Bearing overheating	Excessive tension on belt drive	Check tension of belt and adjust as necessary
	Lubrication fault	Check lubrication frequency and recommended lubricant
Visible cracks in knife	Incorrect grinding or grinding procedure	Check method of grinding and contact our technical sales department
Knives moving on knife seats	Uneven knife seat surfaces	Clean up to provide maximum bearing surface
	Loose knife screws	Knife screws should not be used more than six times. Replace if there is evidence of stretch
Knives breaking	Cracks caused by incorrect grinding	Contact our technical sales department
Excessive knife wear	Open knife setting	Re-set knives
Screen breakage	Incorrectly seated screen	Check that the screen is seated correctly and fully in its cradle

# Chapter 7: Appendix

## 7-1 Recommended Torque for Screws

(Grade 8 alloy steel heat-treated screws)

MM Screw Size	6	8	10	12	16	19	20	24	
Inch Screw Size	1/4	5/16	3/8	7/16	1/2	5/8	3/4	7/8	
Torque Ft. Lbs.	13	26	46	76	110	220	400	635	870

*Note: Threads must be dry. Screw threads should be wiped with an oil-dampened cloth before installation to prevent galling.*

## 7-2 Technical Specifications

### Features

Model	Throat Size	Cutting Chamber Diameter	Throughput	Approx. Weight
37"	18" x 37" (457 x 940mm)	16" (406mm)	2500 lbs./hr (1136 kgs./hr)	11,000 lbs. (5000 kgs.)
50"	20" x 50" (510 x 1270mm)	18" (457mm)	3500 lbs./hr (1591 kgs./hr)	15,000 lbs. (6818 kgs.)

*Specifications*

	<b>Standard</b>	<b>Standard Options</b>
Infeed	Conveyor Feed	Tray and sheet feed; Tray and feed rolls; Pipe Feed
Cutting Chamber Rotor	2-Bed Knife	Hard facing, water cooling, air purge bearings
	Open 3-Knife high shear	5-Knife high shear; 3-Knife steep angle; 5-Knife S/A
Rotor Knives	HCHC	Steep angle, 55 degree (B Series only)
Bed Knives	(2) HCHC	Raised D/S (B Series only)
Screen	3/8" N.H.T.	1/4" and larger, H.T.
Drive Parts	V-Belt	
Electrical Components	NEMA12 with safety locks	
Controls	Customer Supplied	230, 460, or 575 volt, NEMA 12
Labels	Safety/caution/operation labels	
Accessories		Blower, Cyclone, Separator, Conveyor



# 7-3 Drawings

## Dimensions

### 37" Model

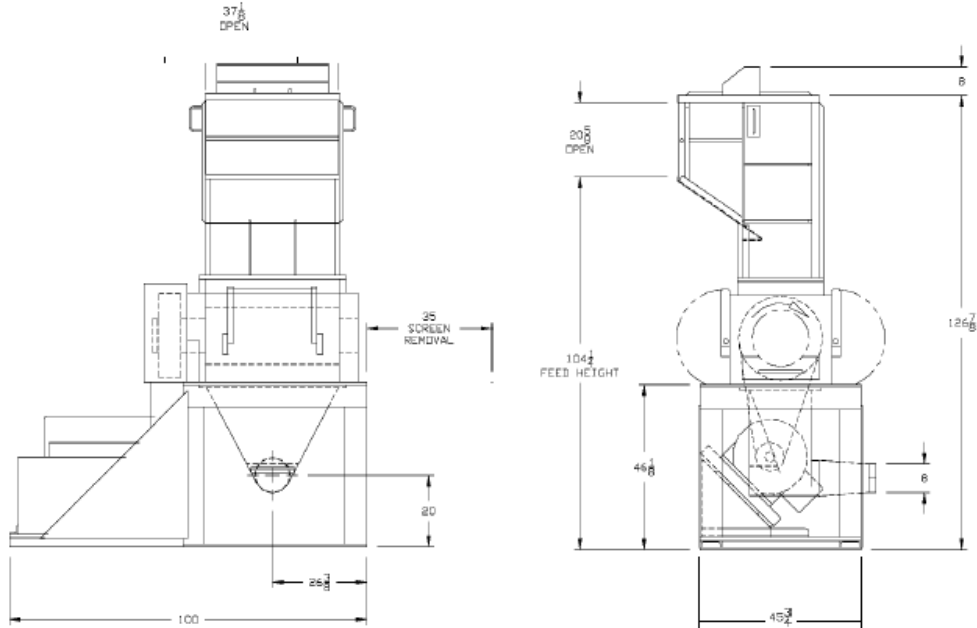

### 50" Model

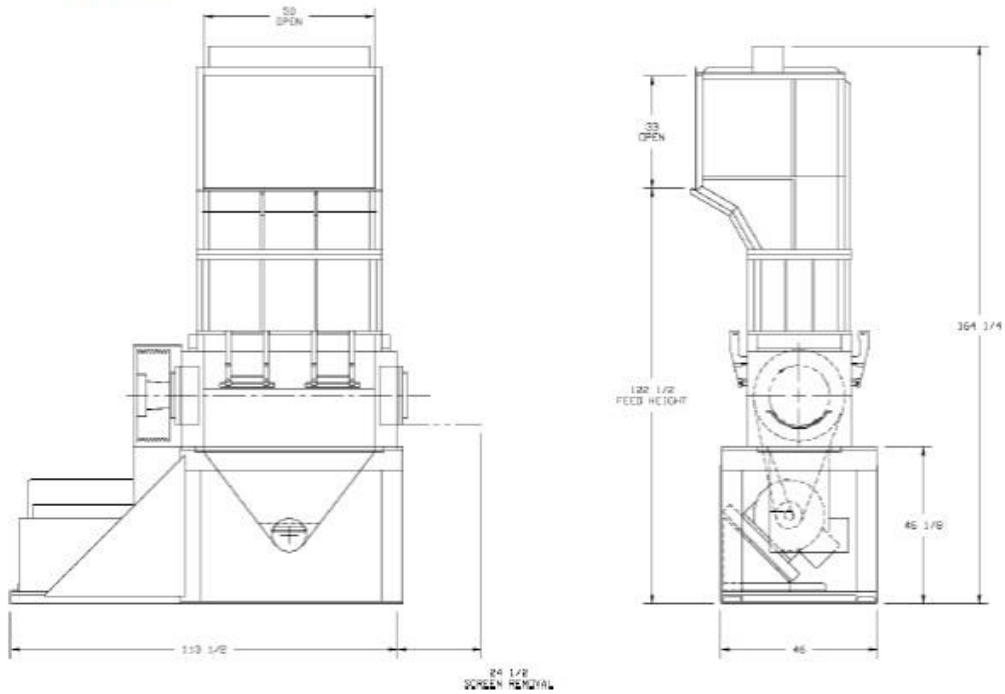

## 7-4 Recommended Spare Parts

### 37" Model

Qty.	Name	Part Number
3	Knife, Rotor – HCHC	B-3 50784-1-2
4	Knife, Bed – HCHC	B-5 0008
20	Scr. Soc. Hd. Cap 3/4 – 16 x 3 (bed knives)	12008-568
20	Washer, Special H.T. 3/4 (bed knives)	D-1757-22
24	Scr. Hex Hd Cap – AS-HT 3/4-16 x 2-1/2 A-490 Grade 8 Full Thread Length (Rotor Knives)	212002-528
12	Scr. Sq. Hd. Set 5/8 – 18 x 3-1/2 (Upstroke & Downstroke bed knife push screws)	12055-324
12	Nut, Hex Jam 5/8 – 18 (Push Screws)	12116-22
12	Scr. Hex Head Cap AS-HT 1/2 – 13 x4 Full Thread (Upstroke & Downstroke bed knife pull screws)	12036-181
2	Brg. Spher. RLR 150 mm Bore – SKF#23030 CC-W33	12406-75
1	Screen 5/16 dia holes – NHT Dia. Patt.	F-350513-0080
4	Stud, Screen retaining – tapered	D-45 1183
1	Bushing, Tapered – Rotor Sheave	A-49245
1	Key, Tapered Bushing	C-4994 1
4	Scr. Hex Hd Cap 1-8 x 4 (Tapered bushing)	12033-700
1	Spacer, Rotor Sheave	B-5 0212
1 Set	Belts, Drive 8-5V-1 180	12219-16
1	Switch, Limit Micro #BZE62RQ8 14	1265 7-20
1	Switch, Limit – Micro #BZV6-2RM	12654-6

## 7-5 Technical Assistance

### **Parts and Service Department**

The ACS Customer Service Group will provide your company with genuine OEM quality parts manufactured to engineering design specifications, which will maximize your equipment's performance and efficiency. To assist in expediting your phone or fax order, please have the model and serial number of your unit when you contact us. A customer replacement parts list is included in this manual for your convenience. ACS welcomes inquiries on all your parts needs and is dedicated to providing excellent customer service.

#### **For immediate assistance, please contact:**

- North, Central and South America, 8am – 5pm CST +1 (800) 483-3919 for drying, conveying, heating and cooling and automation. For size reduction: +1 (800) 229-2919.  
North America, emergencies after 5pm CST (847) 439-5855  
**North America email: [acsuscanadacustserv@corpemail.com](mailto:acsuscanadacustserv@corpemail.com)**
- Mexico, Central & South America  
**Email: [acslatinamericacustserv@corpemail.com](mailto:acslatinamericacustserv@corpemail.com)**
- Europe, Middle East & Africa +48 22 390 9720  
**Email: [acseuropecustserv@corpemail.com](mailto:acseuropecustserv@corpemail.com)**
- India +91 21 35329112  
**Email: [acsindiacustserv@corpemail.com](mailto:acsindiacustserv@corpemail.com)**
- Asia/Australia +86 512 8717 1919  
**Email: [acsasiacustserv@corpemail.com](mailto:acsasiacustserv@corpemail.com)**

### **Sales and Contracting Department**

Our products are sold by a worldwide network of independent sales representatives. Contact our Sales Department for the name of the sales representative nearest you.

Let us install your system. The Contract Department offers any or all of these services: project planning; system packages including drawings; equipment, labor, and construction materials; and union or non-union installations.

#### **For assistance with your sales or system contracting needs please Call:**

North, Central and South America +1 (262) 641-8600 or +1 (847) 273-7700  
Monday–Friday, 8am–5pm CST

- Europe/Middle East/Africa +48 22 390 9720
- India +91 21 35329112
- Asia/Australia +86 512 8717 1919

#### **Facilities:**

ACS offers facilities around the world to service you no matter where you are located. For more information, please visit us at [www.acscorporate.com](http://www.acscorporate.com)

United States:

#### **ACS Schaumburg- Corporate Facility**

1100 E. Woodfield Road  
Suite 588  
Schaumburg, IL 60173  
Phone: + 1 847 273 7700  
Fax: + 1 847 273 7804

Asia/Australia:

#### **ACS Suzhou**

109 Xingpu Road SIP  
Suzhou, China 215126  
Phone: + 86 8717 1919  
Fax: +86 512 8717 1916

India

#### **ACS India**

Gat No. 191/1, Sandbhor Complex  
Mhalunge, Chakan, Tal Khed,  
Dist. Pune 410501, India  
Phone: +91 21 35329112  
Fax: + 91 20 40147576

Europe/Middle East/Africa:

#### **ACS New Berlin- Manufacturing Facility**

2900 S. 160<sup>th</sup> Street  
New Berlin, WI 53151

#### **ACS Warsaw**

Ul. Działkowa 115

35 of 36



**800-243-9226**  
awa  
+2 390 9720  
+90 9724

