

HAMMEL- Shredder VB 950 DK

the "RED GIANT"

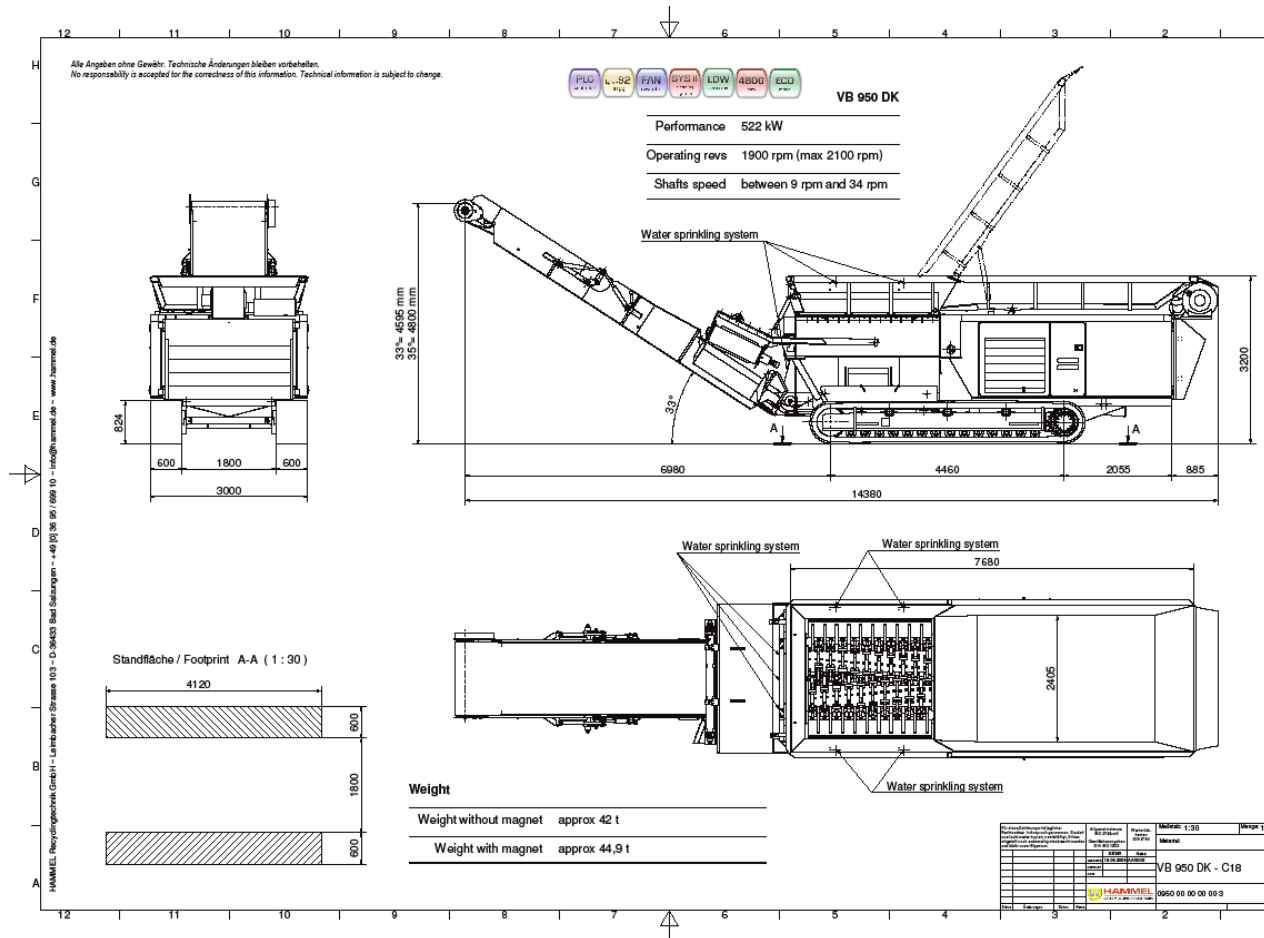

Technical data for VB 950 DK, the "RED GIANT"		
Transport	frame	Self propelled on tracks W: 10'; L: 42'; H: 11'
Drive	engine	Diesel engine CAT C-18
	power	approx. 710 HP
	rpm	approx. 1.900 min ⁻¹
Discharge belt	discharge width	approx. 55"
	discharge height	Step less adjustable, max 15'-9"
Tools	shaft diameter	approx. 34"
(patented)	shaft length	approx. 98 1/2"
	shaft rpm	9 – 34 rpm
	Torque	max. 324,252 foot-pound / 3,891,000 inch-pound
Remote control	type	Active 21-channel system with separate emergency switch
Tilting hopper	volume	approx. 16 –24 cubic yards
Weight	w/out magnet:	app. 95,000 lbs,
	with magnet:	app. 101,500 lbs

Alle Angaben ohne Gewähr. Technische Änderungen bleiben vorbehalten.
 No responsibility is accepted for the correctness of this information. Technical information is subject to change.

PLC controlled
92 Lpm/dB(A)
FAN reversible
SYS II cleaning system
LOW emission
4800 mm
ECO mode

VB 950 DK

Performance	522 kW
Operating revs	1900 rpm (max 2100 rpm)
Shafts speed	between 9 rpm and 34 rpm

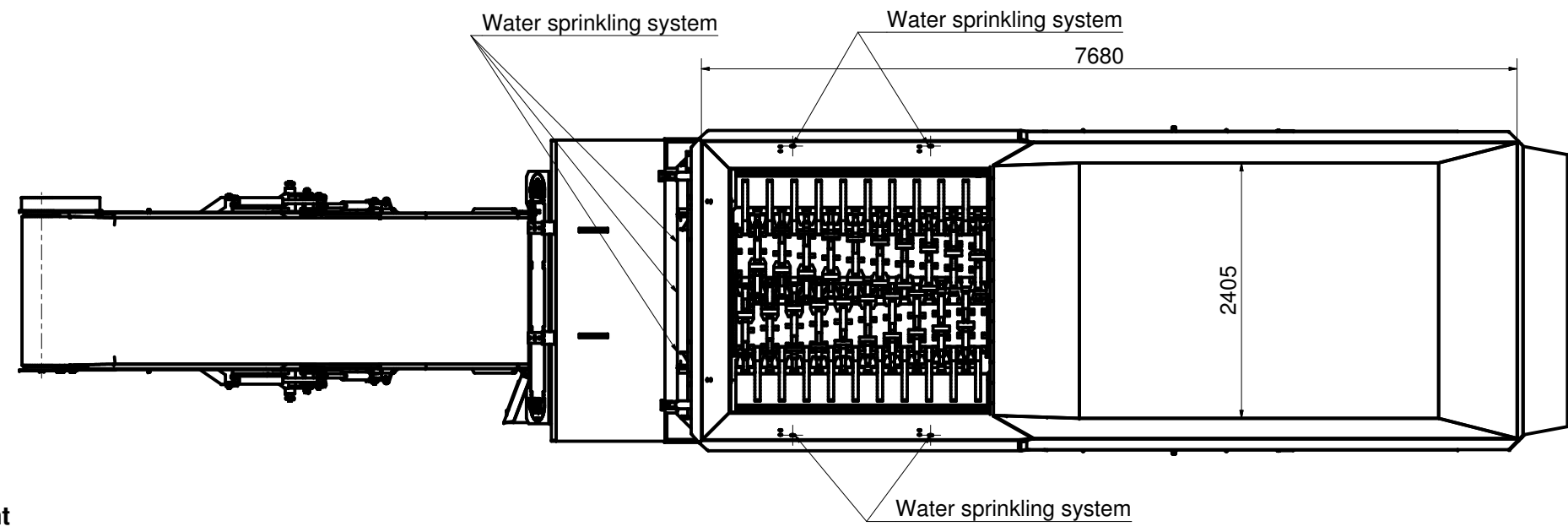
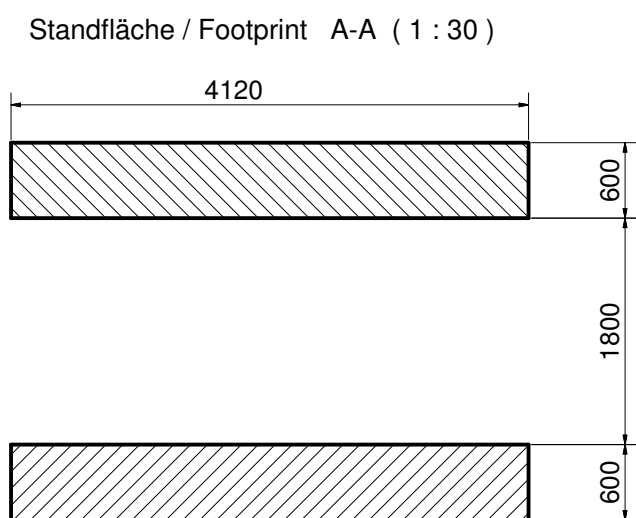
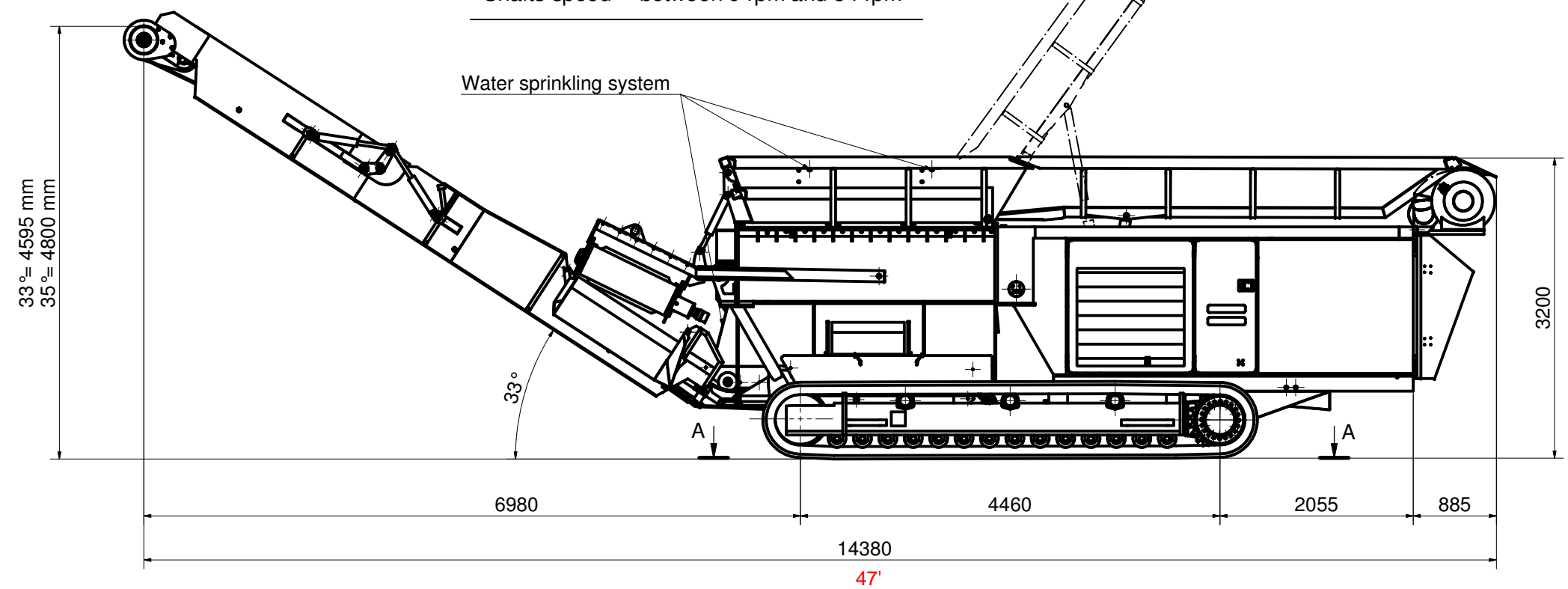
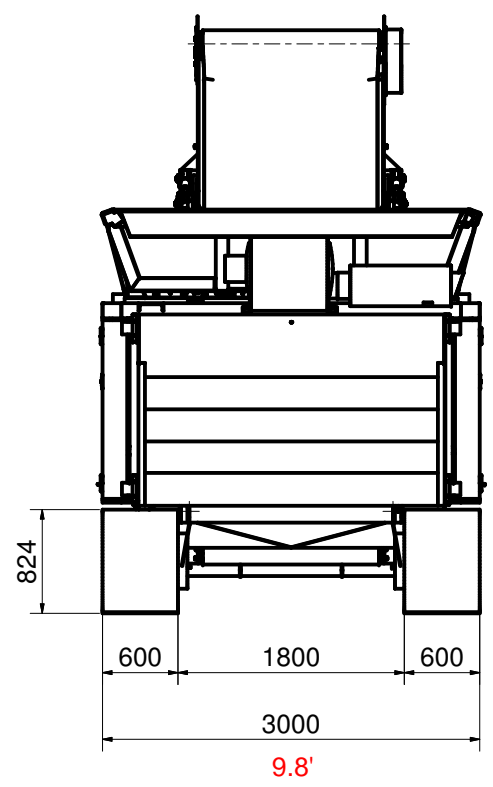

Weight

Weight without magnet	approx 42 t
Weight with magnet	approx 44,9 t

Für diese Zeichnung wird jeglicher Rechtsschutz in Anspruch genommen. Sie darf unerlaubt weder kopiert, vervielfältigt, Dritten mitgeteilt noch anderweitig missbraucht werden und bleibt unser Eigentum.		Allgemeintoleranz ISO 2768-mK Oberflächenangaben DIN ISO 1302	Maßstab: 1:30 Menge: 1
Datum: 15.09.2009 Gezeichnet: AArnold Korrektur: Norm:	Name: AArnold Werkstück-karten DIN 6784	Material: VB 950 DK - C18	
Status: Änderungen: Datum: Name:		HAMMEL RECYCLINGTECHNIK	0950 00 00 00 00 3 1 A1

HAMMEL Recyclingtechnik GmbH ~ Leimbacher Strasse 103 ~ D-36433 Bad Salzungen ~ +49 [0] 36 95 / 699 10 ~ info@hammel.de ~ www.hammel.de

12 11 10 9 8 7 6 5 4 3 2 1

Alle Angaben ohne Gewähr. Technische Änderungen bleiben vorbehalten.
 No responsibility is accepted for the correctness of this information. Technical information is subject to change.

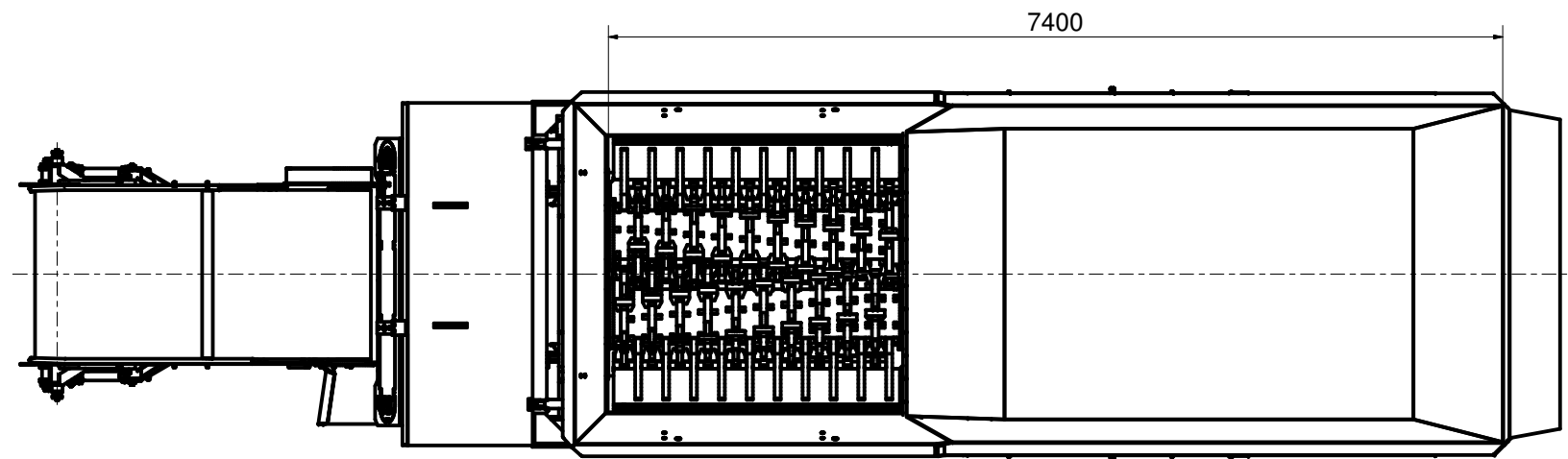
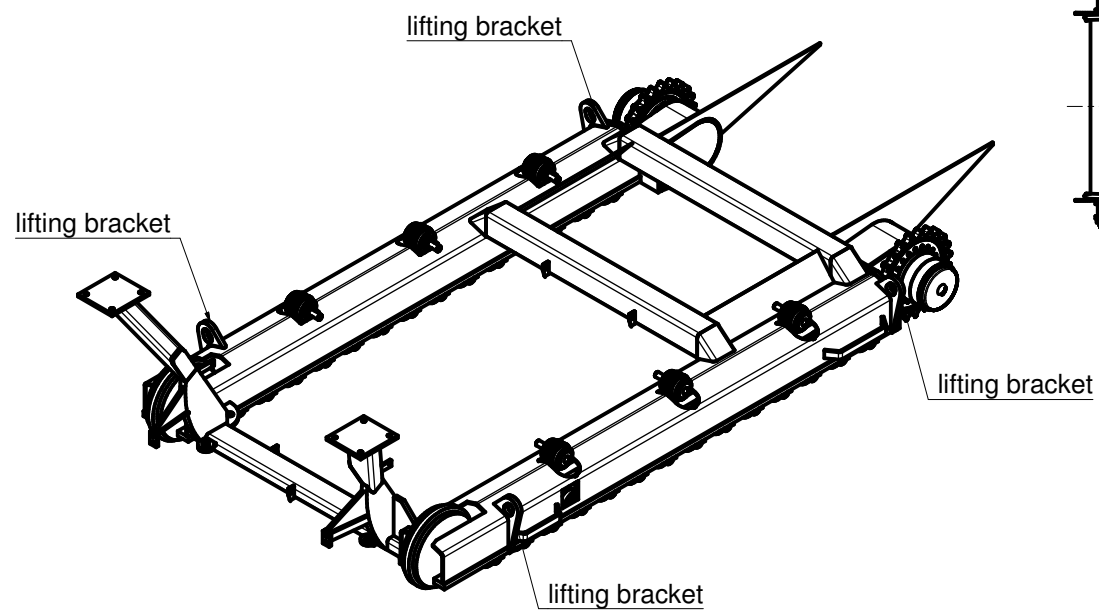
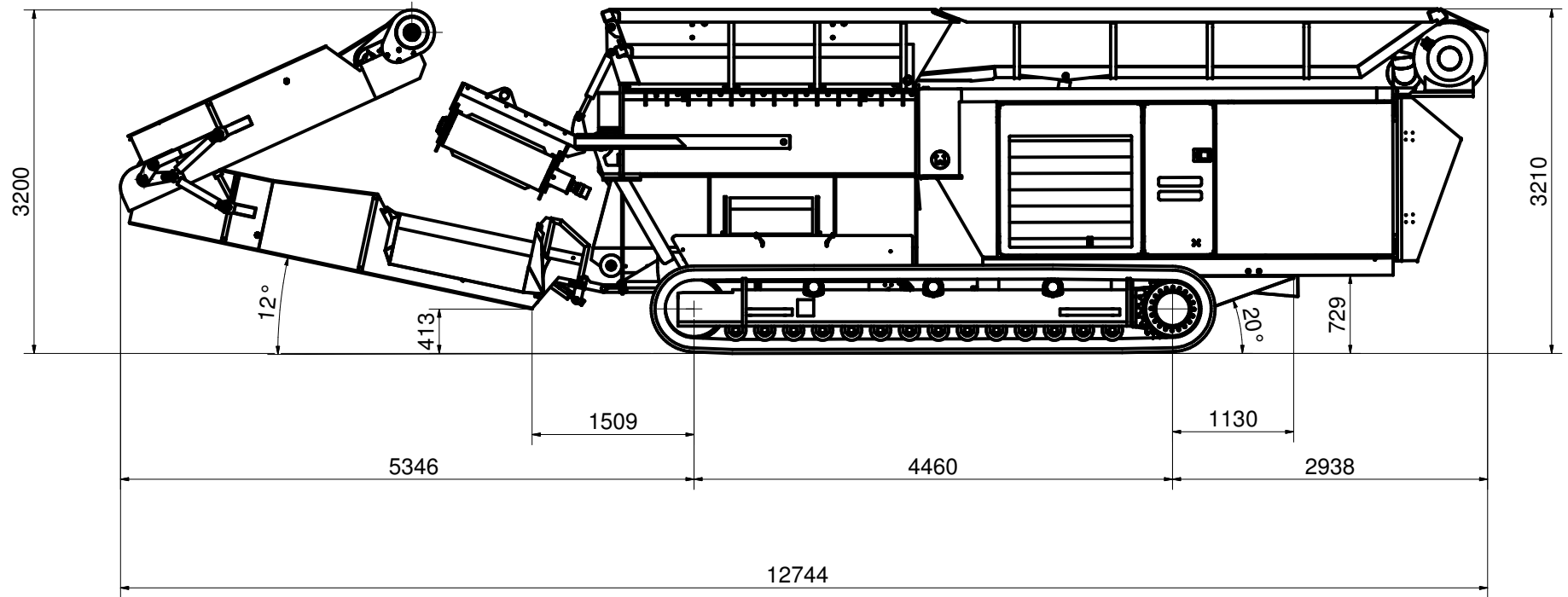
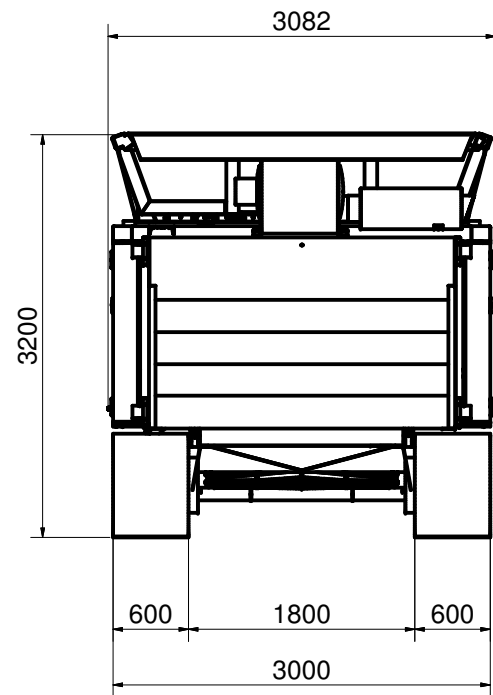

Weight

Weight without magnet approx 42 t

Weight with magnet approx 44,9 t

HAMMEL Recyclingtechnik GmbH ~ Leimbacher Strasse 103 ~ D-36433 Bad Salzungen ~ +49 [0] 36 95 / 699 10 ~ info@hammel.de ~ www.hammel.de

Für diese Zeichnung wird jeglicher Rechtsschutz in Anspruch genommen. Sie darf unerlaubt weder kopiert, vervielfältigt, Dritten mitgeteilt noch anderweitig missbraucht werden und bleibt unser Eigentum.		Allgemeintoleranz ISO 2768-mK Oberflächenangaben DIN ISO 1302	Werkstück- karten DIN 6784	Maßstab: 1:30	Menge: 1
Gesamtheit	Datum	Name	Material:		
Konstruktion	15.09.2009	AArnold	VB 950 DK - C18		
Norm			0950 00 00 00 00 3		
Status		Änderungen	Datum	Name	
					2 A1

12 11 10 9 8 7 6 5 4 3 2 1