

THE DUST DEMOLISHER

THE DUST DEMOLISHER

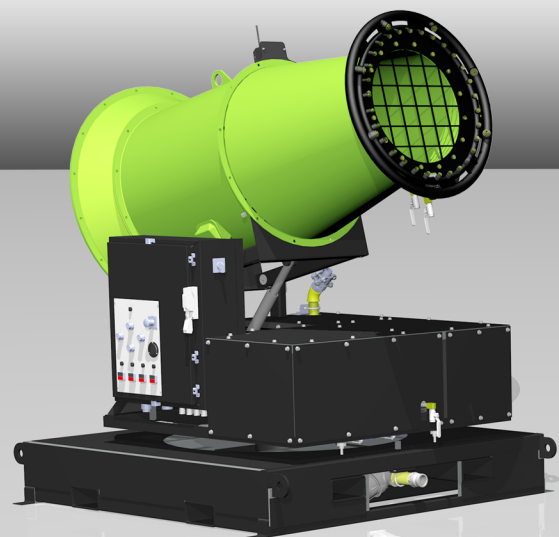

SHARED SPECS

GENERAL SPECIFICATIONS

- Oscillator gives 30-330° of movement
- Electronically controlled aiming for oscillation function
- Powered adjustable angle of throw -10 to +45° of height adjustment
- 330° of powered position adjustment
- Central lubrication where practical using Beka-Max components
- 1,000' line of sight radio remote control
- Single control point for "at machine" operation

NOISE LEVEL

- 0 ft = 104 dBA
- 12 ft = 93 dBA

WATER SPECIFICATIONS

- 30 brass nozzles on primary water ring
- 6 brass nozzles on secondary soaking ring
- Separate ball valve control for each water ring
- Quick disconnect (cam lock) water inlet fitting 2" diameter
- Water boosted by 150 PSI after going through booster pump

POWER SPECIFICATIONS

- 1/4 HP, 480 VAC oscillator motor
- 1.0 RPM rotation speed for oscillation
- Rotation supported by gear driven slewing ring
- 1/2 HP, intermittent duty 120 VAC throw adjustment motor

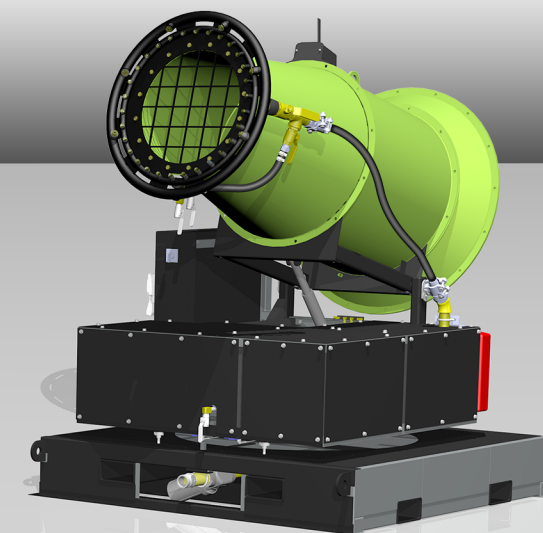

DE-150 specs

Dimensions: 5.2'W x 7.3'L x 6.8'H
Weight: 3,300 lbs

- 17,000 + CFM generated by fan
- In-line filter included (80 mesh, 177 micron)
- 15 HP, 480 VAC, 3-phase fan motor
- 11 HP, 480 VAC, 3-phase for booster pump
- 7,400 feet per minute fan outlet air velocity

DE-200 specs

Dimensions: 5.2'W x 7.3'L x 6.8'H 7.1'H
Weight: 3,400 lbs

- 18,000+ CFM generated by fan
- In-line filter included. (80 mesh, 177 micron)
- 20 HP, 480 VAC, 3-phase fan motor
- 13 HP, 480 VAC, 3-phase booster pump
- 8,100 feet per minute fan outlet air velocity

PRIMARY (30) NOZZLE RING

WATER PRESSURE (PSI)	40	60	80	100	120	140	150
WATER FLOW (GPM)	10.0	12.3	14.1	16.0	17.5	18.7	19.2

SECONDARY (6) NOZZLE RING

WATER PRESSURE (PSI)	40	60	80	100	120	140	150
STANDARD WATER FLOW (GPM)	22	25	29	32	34	37	38

WATER COVERAGE AND THROW

- COVERAGE: 65,000 sq ft
- THROW: 150 ft+

*Water mist throw distance based on 1,000 ft elevation testing

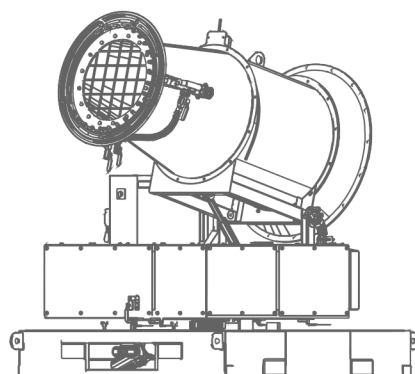

PRIMARY (30) NOZZLE RING

WATER PRESSURE (PSI)	40	60	80	100	120	140	150
WATER FLOW (GPM)	10.0	12.3	14.1	16.0	17.5	18.7	19.2

SECONDARY (6) NOZZLE RING

WATER PRESSURE (PSI)	40	60	80	100	120	140	150
STANDARD WATER FLOW (GPM)	28	32	36	40	43	46	48

WATER COVERAGE AND THROW

- COVERAGE: 115,700 sq ft
- THROW: 200 ft+

*Water mist throw distance based on 1,000 ft elevation testing

