

**AUTO FLATTENING  
(MOBILE)**

**AUTO FLATTENING  
(STATIONARY)**

**FERROUS BALING**

**NON-FERROUS BALING**

**LOOSE SCRAP  
FLATTENING**

**APPLIANCE  
FLATTENING**



# **MAC CORPORATION**

***Setting the standard for  
auto crushing and  
industrial baling.***

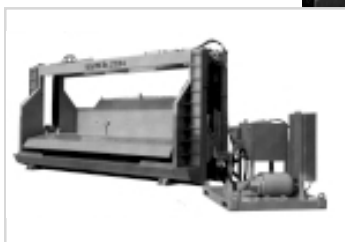

# **MAC Flatteners**

## **Setting performance and durability standards for an entire industry.**

.....

### **The "Big MAC" Flattener**

#### **"Big" Reliability**

Widely recognized as the industry standard, "Big MAC" flatteners combine high performance and low maintenance characteristics in a mobile auto crusher. The result is an unparalleled record for equipment performance: more than 99% of all "Big MAC" flatteners ever made are still at work today.

#### **Wide Lift**

Featuring high-quality, precision cylinders that can be quickly and easily raised for operation or lowered for travel, the "Big MAC" flattener meets the needs of today's mobile scrap processor. Offering a wide, 90-inch lift for easier loading and larger capacities, the "Big MAC" is built to perform. Four automobiles can be easily compacted into dense bundles, reducing both onsite storage demands and transportation costs. A redesigned hydraulic landing gear also speeds setup, while a range of available 165 hp diesel engines — including John Deere and Cummins — affords an unparalleled degree of choice and versatility.

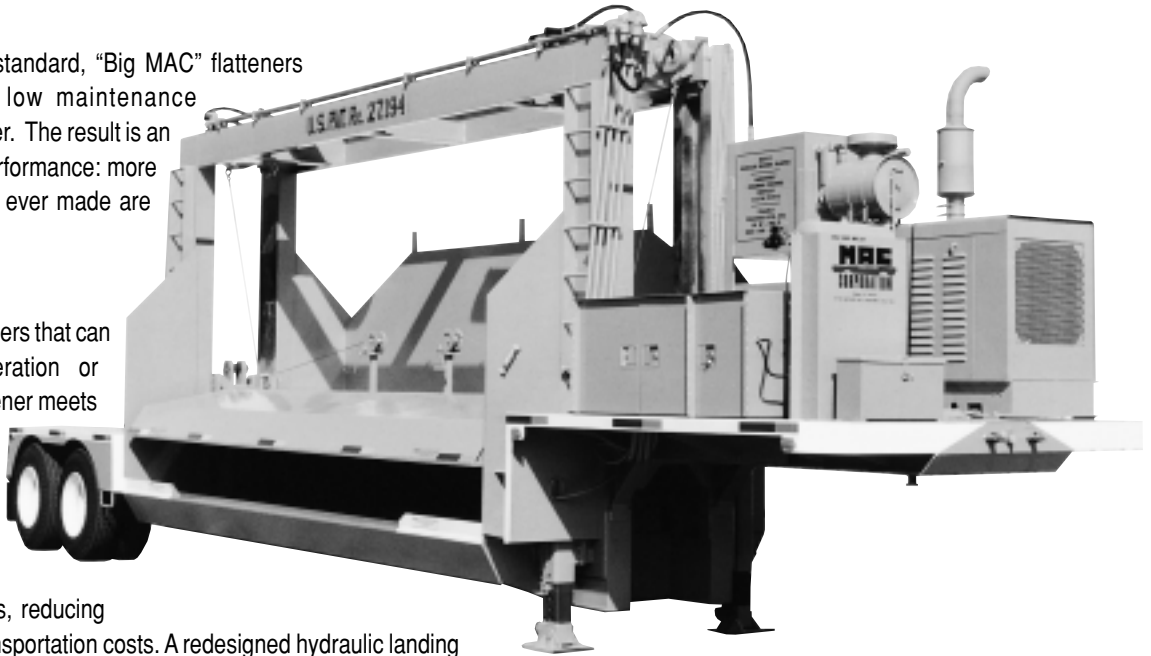

#### **Remote Operation**

Remote operational capability, a standard feature, lowers operational costs by allowing one person to load and operate the crusher. In addition, removing workers from the immediate processing area improves onsite safety.



***Setup, teardown and movement are key to any mobile crushing operation. By nature of their design, "Big MAC" Flatteners afford the highest crushing power, yet are transportable without special permitting. Offered as a standard feature, hydraulically-actuated landing gear (at left) raise and lower quickly, enhancing mobility.***

***Starter switches, throttle control and system gauges, including those monitoring hydraulic system pressures and engine RPM, oil pressure and water temperatures, are easily accessible, yet enclosed for protection from elements.***

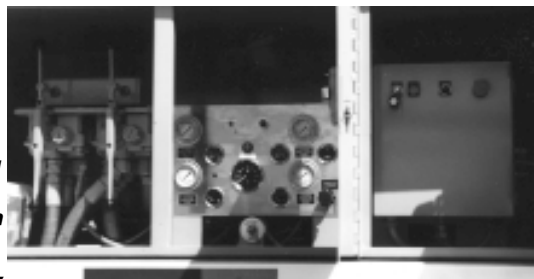



▲  
Utilizing patented crushing technology, the "Big MAC" Mobile Auto Flattener provides unequalled densities. Shown above, independently operating cylinders use a "levering" sequence to maximize flattening action. The combined force of the two cylinders provides more than 300,000 lbs. of crushing power allowing efficient flattening of up to four autos at a time.

▲  
Once crushed, auto hulks can be easily removed from the "Big MAC" using a fork-equipped loader. Every MAC auto flattener is equipped with an oil reclamation system to minimize risk of environmental concerns.

▲  
Because each auto has been effectively flattened, stacks of four, such as that shown above, are tight, neat and easily transportable for loading onto a flatbed for shipment. Tighter stacks mean larger loads without risk of load shift or loss and lower transportation costs.

## "Big MAC" Flattener Specifications

**Bed** — Length ..... 19' 10" (6.0m)  
 Width ..... 7' 6" (2.3m)  
 Lift ..... 7' 6" (2.3m)

**Engine** — John Deere Model 6068T, Cummins Model 6BTA5.9, rated 165 Hp at 2400 rpm.

**Overall** — Length ..... 41' 0" (12.5m)  
 Width ..... 8' 0" (2.4m)  
 Height — travel ..... 13' 5" (4.1m)  
           — operating ..... 20' 7" (6.3m)  
 Weight — operating ..... 56,000 lbs. (25,400kg)

**Hydraulic System** — 90 gpm at 2400 rpm  
 System Pressure — 2400 psi (166 Bar)  
 Force per cylinder — 153,000 lbs. (69,400kg)  
 Total combined cylinder force — 306,000 lbs. (138,801kg)  
 Port reliefs set at 2600 psi (179 Bar)  
 Cycle time — 45 seconds





# The Stationary MAC Flattener

## Power in Place

Offering many of the same performance-based features as its mobile "Big MAC" counterpart, the stationary MAC flattener provides powerful, fast crushing of autos, household appliances and other loose bulky scrap. With a crushing force of 306,000 lbs., four complete automobiles can be tightly compressed. Bulky household appliances,

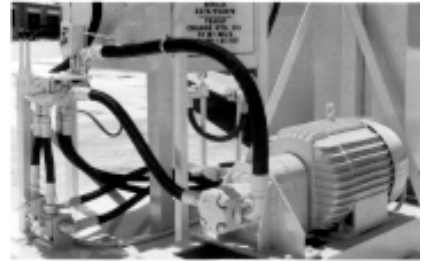

▲  
**Electric power choices available in 240VAC and 480VAC units.**  
**Having separate power plant and main flattener components improves placement options for smaller installations.**

loose automotive scrap and other miscellaneous scrap materials can also be quickly and efficiently crushed. And, of course, flatter scrap means lower transportation costs.

## Improved Potential

Designed for economical operation, the stationary MAC flattener can positively impact even smaller scrap processing facilities. Higher



income potential can be realized by flattening at ideal times, stacking crushed autos to better utilize available yard space, expanding buying potential, taking additional time for engine and parts recovery, and selling at times of higher prices.

Available in both diesel and electric motor configurations, the stationary MAC flattener is ideal for scrap recycling operations in which mobility is not an issue but performance definitely is.

## Stationary MAC Flattener Specifications

<b>Length</b> —	23' 0" (7.0m)
<b>Width</b> —	7' 6" (2.3m)
<b>Height</b> —	(cylinders cradled) 11' 6" (3.5m)
	(cylinders upright) 18' 5" (5.6m)
<b>Weight</b> —	(without powerpack) 45,000 lbs. (20,4112 kg)
	(diesel) 51,000 lbs. (23,133 kg)
	(electric) 49,000 lbs. (22,226 kg)
<b>Lift</b> —	7' 6" (2.3m)

### Additional info:

- Separate hydraulic components and power plant
- Diesel or electric 100 hp engine
- Diesel choices include John Deere Model 6068T and Cummins Model 6BTA 59
- Electric choices include 100 hp, 240VAC and 480VAC, units
- Two 9" bore MAC cylinders
- Crushing force of 306,000 lbs
- Fast 45 second cycle time
- Pressures of 2400 psi @ 1800 rpm (electric); 2400 psi @ 2400 rpm (diesel)

# MAC Model 5200 Baler

## Powerful solutions in ferrous and non-ferrous baling.



### The Workhorse

Developed for high density baling of both ferrous and non-ferrous metal, MAC's Model 5200 excels in a broad range of materials including loose steel sheet, clips and trim stock. A real workhorse, the Model 5200 baler is capable of producing bales measuring 16-inches square by variable lengths at a rate of 55 - 60 per hour. Bale densities vary according to material but average in the 165 lb./cu. ft. range for ferrous material and 50-65 lb./cu. ft. for aluminum.

### User-Friendly Baling

Designed for ease of use, the MAC Model 5200 offers both semi- and full-automatic operating modes. Built to withstand the rigors of metal baling operations, all surfaces which come

in contact with moving plates are lined with a wear plate of abrasion-resistant,

high-alloy steel. Each of the two rams is stress-relieved and features box-type steel weldments for added durability. As with all MAC equipment, mobile models are available.

### Reduced Pre-Processing

Oversized material is first downsized by a shear bar capable of producing a shearing force in excess of 380 tons. Doing so eliminates the need for most pre-processing, thereby further streamlining scrap processing operations and improving hourly tonnages.

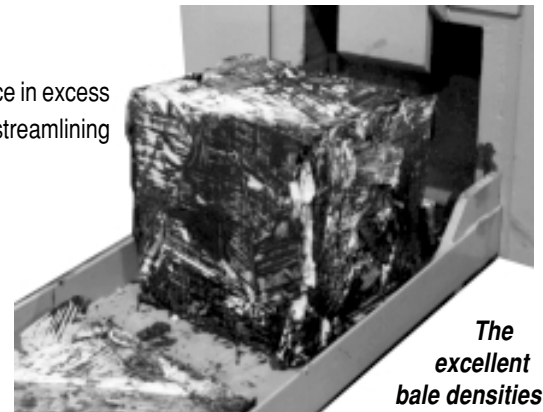

The excellent bale densities offered by the

MAC Model 5200 — up to 165 lbs./cu. ft. for ferrous metals — make it ideal for a broad range of scrap processing operations.

## Model 5200 Baler Specifications

Length — (overall) .....	26' 6" (8.06m)
Width — (including side ram) .....	19' 7" (5.9m)
Height — .....	9' 0" (2.7m)
Weight — (approx.) .....	75,000 lbs. (34,020 kg)

### Hopper and Charging Box

Hopper — (standard) .....	72" wide X 118" long
Hopper — (optional) .....	up to 92" wide X 124" long
Charging Box — .....	52" wide X 16" deep X 112" long
Volume — .....	54 cubic feet
Clear Opening — .....	52" wide X 85" long

## Custom Capabilities in Baling

MAC Corporation and each of its divisions prides itself in its ability to meet special processing needs. Custom equipment and modifications to existing equipment — like the mobile Model 5200 Baler shown at right — are examples of this commitment to meeting customers' needs.



# **Support and More**

## **Additional equipment and services tell the whole MAC story**

### **MAC Forks**

An operation is only as good as the equipment supporting it and that goes well beyond capital equipment such as flatteners, cranes, shears and balers. MAC forks, designed and manufactured for heavy-duty use, have proven ideal at supporting crusher loading and unloading functions at scrap auto yards the world over.

#### **Standard and Custom**

MAC forks are available in sizes created to fit a range of existing front end loaders and can also be custom-designed to meet customer specifications. Built to easily handle lifts up to 15,000 lbs., MAC forks augment the high performance capabilities of MAC's other products at work in the yard.

#### **MAC Quality**

Like every item manufactured bearing the MAC name, MAC forks are built to the highest possible standards: our own. How reliable a barometer are those standards? To date, more than 1600 sets of forks have been fabricated for front-end loaders worldwide and many standard brand loaders sold today are fitted with MAC forks as original equipment.



### **MAC Designs for Performance**

Equipment performance begins with, and is linked to, equipment design. MAC Corporation's design engineers use the latest available technology and a thorough knowledge of materials to ensure that every MAC unit provides maximum performance and durability.

Product modifications to suit individual conditions are frequently incorporated into existing crusher and baler designs, thereby making custom solutions to specific problems readily available.

### **Manufacturing Excellence**

At MAC Corporation's Grand Prairie, Texas, manufacturing facility, the latest in manufacturing and assembly technologies are teamed up with an intangible: the commitment to excellence inherent in the MAC manufacturing workforce. The result of this pairing is the industry's highest level of performance and reliability.



### **Warranty and Service**

Every MAC flattener, baler, and fork assembly is backed by one of the industry's best warranties designed to provide peace of mind long after the initial installation. In situations in which follow-up service is needed, however, a highly-trained staff of service technicians is readily available to ensure downtime is minimized. A fully-stocked inventory of parts also ensures that customer needs are quickly met. In most cases, replacement parts are enroute to the customer within hours of the initial call.

MAC Corporation of America and its Granutech-Saturn Systems and Saturn Shredders divisions represent one of the world's largest manufacturers of equipment and systems for material recycling. Since 1965, MAC Corporation has established itself as an industry leader through its commitment to quality equipment for the recycling industries both in the U.S. and abroad.

.....

.....

**GRANUTECH**  
**SATURN**  
SYSTEMS

.....

**W**hen size reduction needs call for secondary processing, one-step reduction and sizing or granulation and powderization, Granutech-Saturn Systems, a division of MAC Corporation, has the solutions.

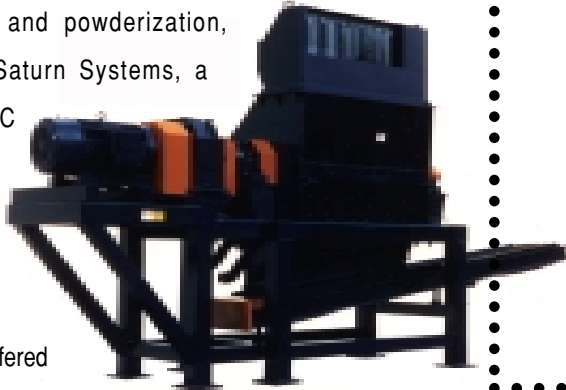

Equipment offered by Granutech-Saturn

Systems includes: the Grizzly processor (shown above); Roto-Grind single rotor shred/sizing units; and the Granutech G-3 granulator, which, with available options, can produce material as fine as 30-mesh. All Granutech-Saturn Systems equipment is offered in a variety of models and sizes to best meet your processing needs.

.....

**MAC**  
CORPORATION

.....

**A**s a stand-alone company, MAC Corporation manufactures automobile flatteners, including the industry standard "Big MAC" flattener, as well as balers for ferrous and non-ferrous compaction. All MAC equipment is offered in stationary and mobile configurations.

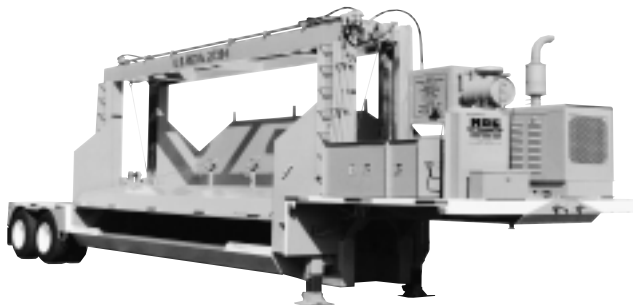

.....

**SATURN**  
**SHREDDERS**

.....

**T**he Saturn Shredders Division of MAC Corporation has been providing quality solutions to shredding problems for more than two decades. Today Saturn offers the broadest range of choices possible for use in the widest range of applications and industries. Available in sizes from 50 hp to over 1000 hp, Saturn Shredders combine the latest in design and manufacturing technology. The result is equipment that provides unmatched throughputs with a reduction in both downtime and maintenance costs.



MAC Corporation and its Saturn Shredders and Granutech-Saturn Systems Divisions, offer proven solutions in the broadest range of applications including:

**AUTO FLATTENING**

**FERROUS/NONFERROUS  
BALING**

**WOOD WASTE GRINDING**

**TIRE RECYCLING**

**PRE-INCINERATION  
MSW/OBW**

**PLASTICS RECYCLING**

**MSW PROCESSING**

**THIN FILM PROCESSING**

**DRUM SHREDDING**

**ELECTRONIC SCRAP**

**C/D WASTE**

**WIRE/CABLE**

**IN-PLANT WASTE**

**PRODUCT DESTRUCTION**

**HAZ-WASTE**

**NUCLEAR LOW-RAD**

**OIL FILTER RECOVERY**

**PALLET SHREDDING**

**and YOUR APPLICATION**

**Contact MAC Corporation today!**



***MAC Corporation of America***

201 East Shady Grove Road  
Grand Prairie, Texas 75050

Phone: (972) 790-7800 Fax: (972) 790-8733

Visit us at our website [www.mac-corp.com](http://www.mac-corp.com)

E-mail: [sales@granutech.com](mailto:sales@granutech.com)

